

OWNER'S MANUAL

AIM8 SERIES

AIM8 One / AIM8 Two / AIM8 Three / AIM8 Four / AIM8 Five

High Fidelity Pivoting In-Ceiling Speaker System

Congratulations on purchasing SpeakerCraft's AIM8 Series of architectural loudspeakers. The AIM8 Series features fully pivoting woofers and independently pivoting tweeters, allowing the entire speaker to be aimed toward the listener.

SPEAKER PLACEMENT

When following the below recommendations, please keep in mind that placement is always in the ceiling. AIM8 speakers can be used as a pair for stereo listening, or for all five channels of a home theater system: front left and right, center, and rear left and right.

SpeakerCraft recommends the use of a qualified custom installation specialist when installing your AIM8 speakers. If you need assistance in locating an installer, please contact SpeakerCraft at 1-800-448-0976.

1. Determine Your Primary Listening Area

The area where you will most likely be sitting when listening to your speakers is your primary listening area.

2. Placement of Stereo Pair / Front Channels for Home Theater

Consider how far apart the speakers should be. To do this, think of your listening area as one tip of a triangle with each leg of the triangle being equal. See speakers FL (front left) and FR (front right) in Figure 1. Place the speakers as close as possible to the two points they represent on the triangle.

If the speakers are to be part of a home theater speaker system, they should be placed as close as possible to the area above the screen. However, in some cases it may be better to place the speakers farther away from the screen in order to maximize speaker separation. An example of a case when this would be desirable is when the television is positioned directly in a corner (See Figure 2).

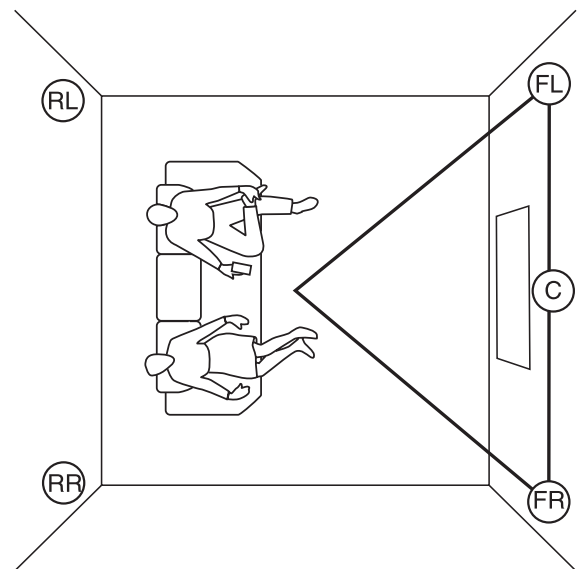

Figure 1

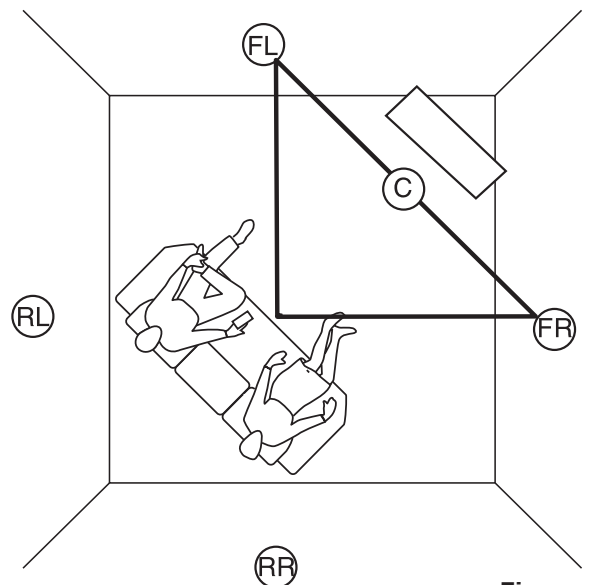

Figure 2

3. Placement of Center Channel for Home Theater

Place the center channel speaker in line between the front left and right speaker directly above the screen. See C (center) in Figure 1.

4. Placement of Rear Channels for Home Theater

Rear channels should be placed behind the listening area. See RL (rear left) and RR (rear right) in Figure 1.

5. Checking for Obstructions

Before confirming the placement of the speakers, you should carefully consider the location of ceiling joists, electrical, plumbing and other fixtures that may get in the way. If you are installing the speakers into an existing ceiling, you can locate obstructions by noting the placement of fixtures and, if possible, gaining access to an attic or crawl space for further analysis. A good stud-finder, found at any building supply store, will help you determine where the joists are located in the ceiling.

INSTALLATION CONSIDERATIONS

Prior to the actual installation of the speakers, it will be necessary to run cables to the speaker location. See your Authorized SpeakerCraft dealer for more information on cable installation. After the cable has been installed, you are ready to mount the speakers.

Preparation for and mounting of the speakers can happen at two different stages. If you are building a new ceiling, follow the section titled **INSTALLATION PREPARATION - NEW CONSTRUCTION**. If you are placing the speakers into an existing ceiling, follow **INSTALLATION PREPARATION - FINISHED CEILING**. There are different considerations for each application. Please carefully follow the recommendations for your application.

INSTALLATION PREPARATION - NEW CONSTRUCTION

When installing the speakers into a newly built ceiling, please follow these instructions carefully:

1. Determine Placement

Determine where in the ceiling the speakers will be placed using the recommendations under **SPEAKER PLACEMENT**. Pay careful attention to the section on avoiding obstructions.

2. Mount InstaLLock Bracket

For best results, mount the SpeakerCraft InstaLLock New Construction Brackets for the AIM8 Series (Part No. BKT90681) following the instructions included with the bracket.

3. The Location is Ready for Drywall

The bracket provides a stable opening around which the drywall installer can cut out an opening, providing a perfect location for installation of the AIM8 Series speaker.

INSTALLATION PREPARATION - FINISHED CEILING

When the speakers will be installed into a finished ceiling, please follow these instructions carefully:

1. Determine Placement

Determine where in the ceiling the speakers will be placed using the recommendations under **SPEAKER PLACEMENT**. Pay careful attention to the section on avoiding obstructions.

2. Locate Obstructions

Find the joists nearest the desired speaker mounting location. The use of a good stud-finder tool is highly recommended for this procedure. Make sure that there are no joists or obstructions where you plan to install the speaker. Read "Checking for Obstructions" under the section **SPEAKER PLACEMENT**.

3. Trace Template

Place the cut-out template at the location you have decided to place the speaker. Use a few pieces of tape or small tacks to hold the template in place. Trace an outline on the ceiling with a pencil.

4. Cut the Hole

CAUTION: This is the most important part of the entire installation. If you are not certain whether or not an obstruction exists behind the desired mounting area, you should start by cutting a small hole in the center of your penciled mounting hole with a drywall saw. Cut at a 45° angle towards the inside of the hole (See Figure 3). Cutting the small hole at this angle will make drywall repair much easier as the piece cut out can be installed neatly back into the hole. Once you have determined there are no obstructions in your desired mounting location, start cutting the finished hole at a 90° angle to the ceiling surface.

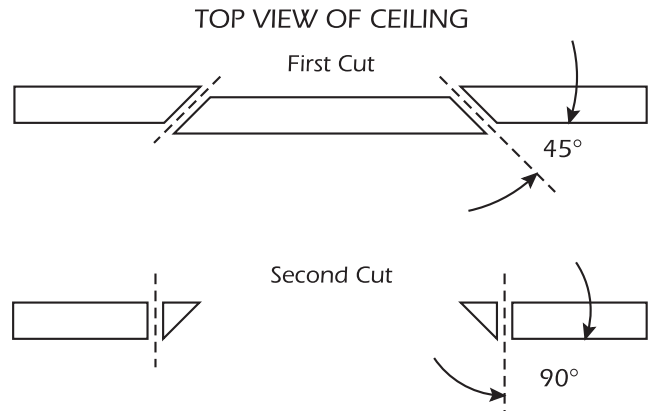

Figure 3

SPEAKER INSTALLATION

Note: Your CRS8 Series speakers may have come with the optional Jawz™ speaker wire connector. Before using Jawz™, please follow the instructions included with the connector.

The unique integral four foot mounting system incorporated into each speaker allows for quick installation following these easy steps:

1. If the grille is on the speaker, remove it. It may be necessary to push one or two of the mounting screws and its attached foot towards the baffle and against the inside surface of the grille to force the grille out of its retaining groove.
2. Attach the speaker cable (observing the proper polarity with your amplifier: + to + and - to -). Make sure the left channel of the amplifier is connected to the left speaker, and the right channel is connected to the right speaker.
3. Make sure the mounting feet are turned inward to clear the opening, and insert the speaker into the ceiling. Position the speaker into the hole. **Note:** The flange of the speaker is designed to flex and conform to any small imperfections in the ceiling surface. Tighten the 4 screws on the front of the baffle only enough to make the flange become snug against the ceiling. As you tighten the screws, the feet will automatically flip into an outward position (See Figure 4), clamping the drywall between the feet and the flange.

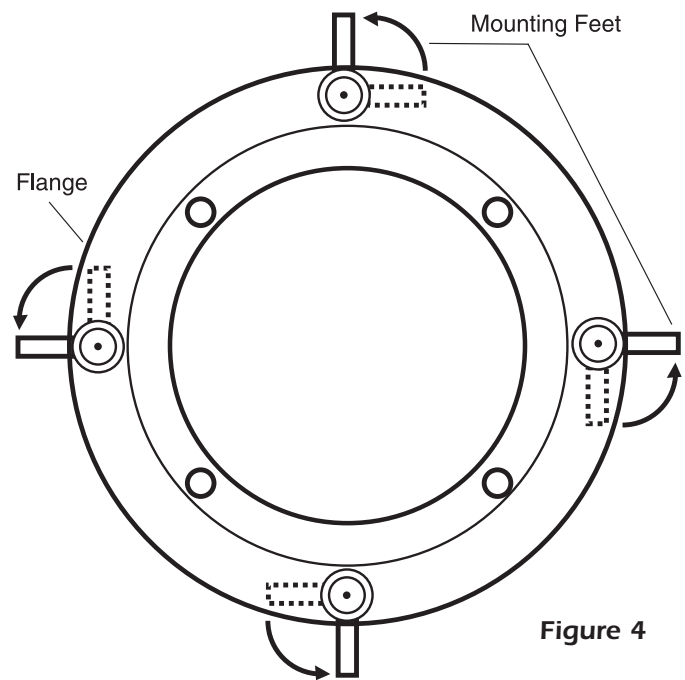

Figure 4

CAUTION: Over tightening may warp the baffle, crack the ceiling, cause the flange to distort, and make the grille difficult to install.

PAINTING THE SPEAKERS

If you plan to paint your speakers, we recommend that it be done prior to installation. If you decide to paint your speakers sometime in the future, it is best to remove them by simply reversing the steps for **SPEAKER INSTALLATION** listed above. When painting the speakers, the paint masks provided in the carton must be installed in place of the grille. The grilles can also be painted. However, great care should be taken not to clog the holes, as this will greatly reduce the sound quality of the speakers. Before painting the grilles, remove the material under grille. Place this material back in place once the grille has been painted. SpeakerCraft recommends only light spray painting using 5 parts thinning agent to 1 part paint. Do not paint the grilles while they are attached to the speaker. If it is necessary to paint the material under the grille, follow the same procedure used to paint the grilles.

SPEAKER ADJUSTMENT

1. Adjusting the AIM8 Mechanism

The woofer can be pivoted to best direct the sound towards the listener. The woofer easily rotates and pivots to almost any position desired. Simply apply pressure with fingertips to the outer surface of the PivotBall and move the speaker to the desired position (See Figure 5).

2. Adjusting the Pivoting Tweeter

Once the woofer is positioned, further refinement can be made by pointing the tweeter towards the listener. Gently pivot the tweeter to point it in the desired direction (See Figure 6).

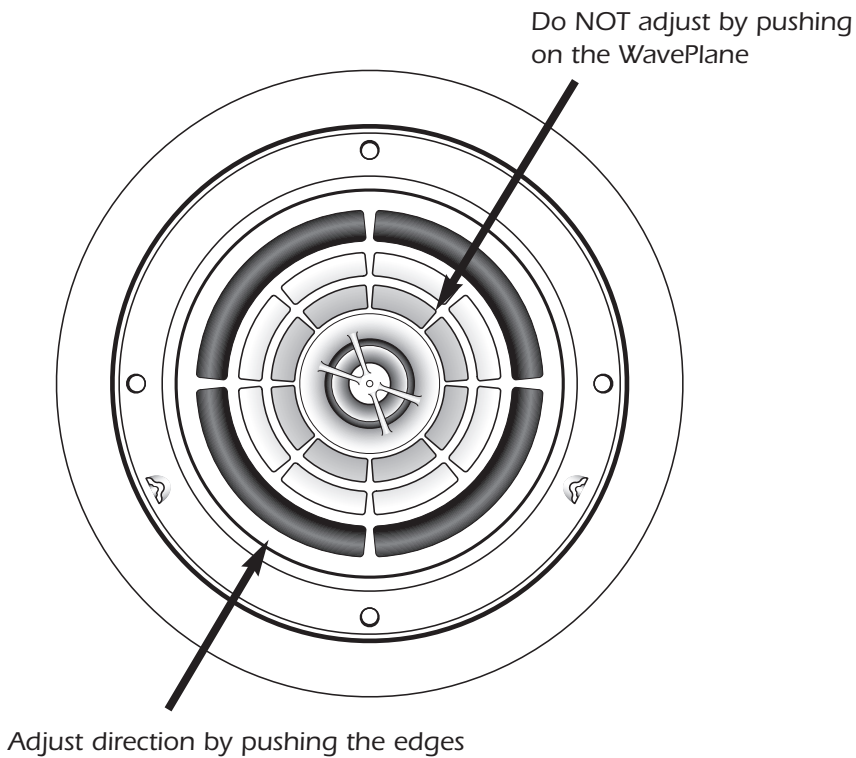

Figure 5

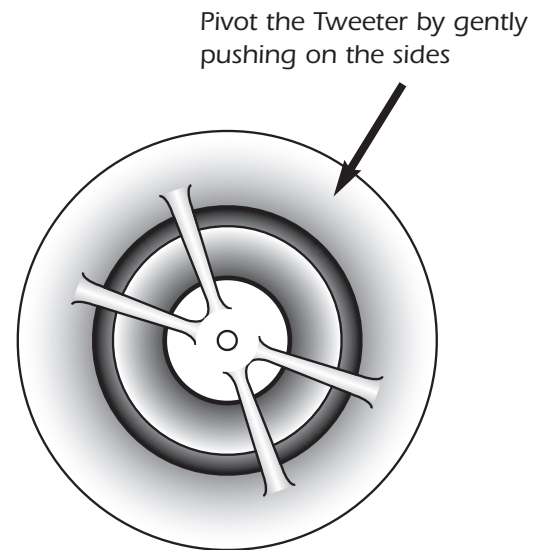

Figure 6

ADJUSTING THE FREQUENCY RESPONSE (AIM8 Two, Three, Four and Five Only)

The output of the woofer and tweeter on the AIM8 Two, Three, Four and Five can be adjusted to suit any environment. In general, we recommend leaving all of the adjustments at the flat (0dB) setting. To determine which settings will be appropriate for your speakers, you may need to experiment until the desired sound is achieved. Use the chart below to determine the result of the setting you select.

Selecting a Setting on AIM8 Two, Three, Four and Five

To select a setting, simply use a finger to move the switches mounted on the inner side of the speaker to the desired setting (See Figure 7).

AIM8 Two: Treble adjustment Only

AIM8 Three, Four and Five: Treble and Bass adjustments

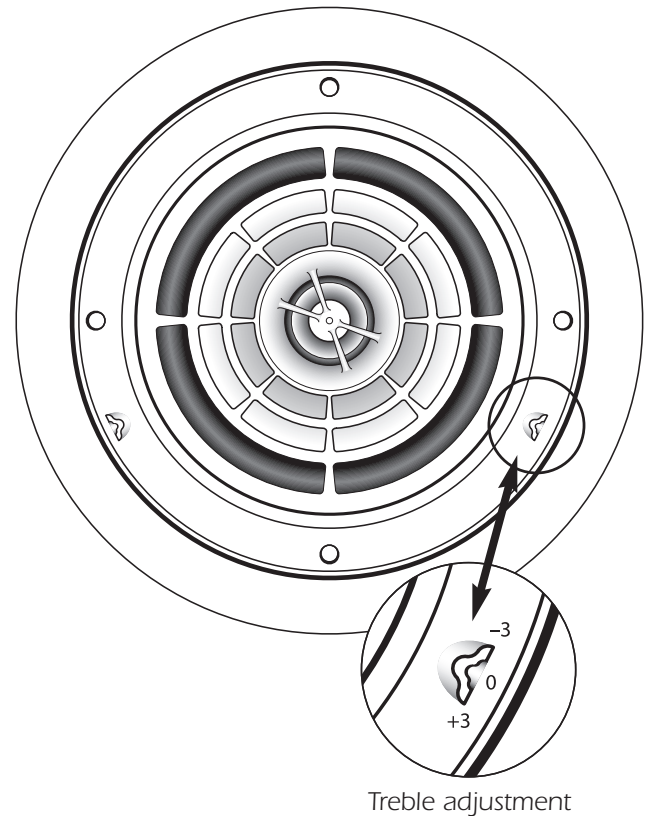

Figure 7

Frequency Settings

When selected, the settings will have the following result:

- 3dB: Reduces the loudness of the selected frequency (bass & treble)
- 0dB: The selected frequency (bass & treble) remains at neutral level
- +3dB: Increases the loudness of the selected frequency (bass & treble)

When adjusting the bass frequency, the impedance will be affected as indicated below. Be sure to stay within the impedance guidelines of the amplifier you will be using to power your system.

- 3dB: The impedance is 8 Ω
- 0dB: The impedance is 6 Ω
- +3dB: The impedance is 4 Ω

SPEAKER SPECIFICATIONS

	AIM8 One	AIM8 Two	AIM8 Three
Speaker Type:	Fully Pivoting In-Ceiling	Fully Pivoting In-Ceiling	Fully Pivoting In-Ceiling
High Frequency Driver:	Independently pivoting 1" Treated Silk Dome Tweeter mounted onto SpeakerCraft's PivotBall	Independently pivoting 1" Treated Silk Dome Tweeter, mounted onto SpeakerCraft's PivotBall	Independently pivoting 1" Treated Silk Dome Tweeter, mounted onto SpeakerCraft's PivotBall
Low Frequency Driver:	Independently pivoting and rotating 8" Injection Molded Polypropylene Cone Woofer, mounted in an assembly that allows the woofer to be pointed as desired	Independently pivoting and rotating 8" Resin Reinforced Fiberglass Cone Woofer mounted in an assembly that allows the woofer to be pointed as desired	Independently pivoting and rotating 8" Aluminum Cone Woofer mounted in an assembly that allows the woofer to be pointed as desired
Impedance:	8 Ω	8 Ω	8/6/4 Ω depending on switch settings
Sensitivity:	88dB 1W/1m	88dB 1W/1m	89dB 1W/1m
Frequency Adjustments:	None	Front mounted treble switch that allows the treble to be set at one of 3 positions: -3dB, flat, +3dB	Front mounted treble / bass switch allows the treble / bass to be set at one of 3 positions: -3dB, flat, +3dB
Frequency Response:	40Hz - 20kHz \pm 2dB	40Hz - 20kHz \pm 2dB	37Hz - 20kHz \pm 2dB
Power Recommendations:	5 - 100 watts (undistorted)	5 - 100 watts (undistorted)	5 - 100 watts (undistorted)
Diameter x Depth:	11 ¹ / ₆ " x 5 ¹ / ₂ "	11 ¹ / ₆ " x 5 ¹ / ₂ "	11 ¹ / ₆ " x 5 ¹ / ₂ "
Cut-out Diameter:	9 ³ / ₄ "	9 ³ / ₄ "	9 ³ / ₄ "
	AIM8 Four		AIM8 Five
Speaker Type:	Fully Pivoting In-Ceiling		Fully Pivoting In-Ceiling
High Frequency Driver:	Independently pivoting 1" Aluminum Dome Tweeter, mounted onto SpeakerCraft's PivotBall		Independently pivoting 1" Aluminum / Magnesium Dome Tweeter, mounted onto SpeakerCraft's PivotBall
Low Frequency Driver:	Independently pivoting and rotating 8" Aluminum/Magnesium Cone Woofer, mounted in an assembly that allows the woofer to be pointed as desired		Independently pivoting and rotating 8" Kevlar Cone Woofer mounted in an assembly that allows the woofer to be pointed as desired
Impedance:	8/6/4 Ω depending on switch settings		8/6/4 Ω depending on switch settings
Sensitivity:	90dB 1W/1m		91dB 1W/1m
Frequency Adjustments:	Front mounted separate bass and treble switches that allow the bass and treble to be set at one of three positions: -3dB, flat, +3dB.		Front mounted separate bass and treble switches that allow the bass and treble to be set at one of three positions: -3dB, flat, +3dB.
Frequency Response:	35Hz - 20kHz \pm 2dB		33Hz - 20kHz \pm 2dB
Power Recommendations:	5 - 100 watts (undistorted)		5 - 100 watts (undistorted)
Diameter x Depth:	11 ¹ / ₆ " x 5 ¹ / ₂ "		11 ¹ / ₆ " x 5 ¹ / ₂ "
Cut-out Diameter:	9 ³ / ₄ "		9 ³ / ₄ "

In our attempt to constantly improve our products, features and specifications are subject to change without notice.

LIMITED LIFETIME WARRANTY

SpeakerCraft Inc. warrants to the original retail purchaser *only* that this SpeakerCraft product will be free from defects in materials and workmanship, provided the speaker was purchased from a SpeakerCraft Authorized Dealer.

Defective products must be shipped, together with proof of purchase, prepaid insured to the SpeakerCraft Authorized Dealer from whom they were purchased, or to the SpeakerCraft factory at the address listed on this installation instruction manual. Freight collect shipments will be refused. It is preferable to ship this product in the original shipping container to lessen the chance of transit damage. In any case, the risk or loss or damage in transit is to be borne by the purchaser. If, upon examination at the Factory or SpeakerCraft Authorized Dealer, it is determined that the unit was defective in materials or workmanship at any time during this warranty period, SpeakerCraft or the SpeakerCraft Authorized Dealer will, at its option, repair or replace this product at no additional charge, except as set forth below. If this model is no longer available and can not be repaired effectively, SpeakerCraft, at its sole option may replace the unit with a current model of equal or greater value. In some cases where a new model is substituted, a modification to the mounting surface may be required. If mounting surface modification is required, SpeakerCraft assumes no responsibility or liability for such modification. All replaced parts and product become the property of SpeakerCraft Inc. Products replaced or repaired under this warranty will be returned to the original retail purchaser, within a reasonable time, freight prepaid.

This Warranty does not include service or parts to repair damage caused by accident, disaster, misuse, abuse, negligence, inadequate packing or shipping procedures, commercial use, voltage inputs in excess of the rated maximum of the unit, or service, repair or modification of the product which has not been authorized or approved by SpeakerCraft. This Warranty also excludes normal cosmetic deterioration caused by environmental conditions. This Warranty will be void if the Serial Number on the product has been removed, tampered with or defaced.

This Warranty is in lieu of all other expressed warranties. If the product is defective in materials or workmanship as warranted above, the purchaser's sole remedy shall be repair or replacement as provided above. In no event will SpeakerCraft be liable for any incidental or consequential damages arising out of the use or inability to use the product, even if SpeakerCraft Inc. or a SpeakerCraft Inc. Authorized Dealer has been advised of the possibility of such damages, or for any claim by any other party. Some states do not allow the exclusion or limitation of consequential damages, so the above limitation and exclusion may not apply.

All implied warranties on the product are limited to the duration of this expressed Warranty. Some states do not allow limitation on the length of an implied warranty. If the original retail purchaser resides in such a state, this limitation does not apply.



SpeakerCraft offers a variety of accessories to make your installation of these speakers and other SpeakerCraft products easy, economical, and professional. Contact your authorized SpeakerCraft Dealer for more information.

Should you have any questions regarding this, or any other SpeakerCraft product, please call our toll-free service hotline at 1-800-448-0976. We are available to assist you every weekday, except holidays, between the hours of 7:00 a.m. and 5:00 p.m. PST.

