

10/100Mbps 4-Port Internet Gateway

APPLICATION

Leviton's 10/100Mbps 4-Port Internet Gateway allows multiple users to utilize a single, secure, high-speed broadband (DSL and cable) Internet connection and creates a private network for home, small office or school environments.

STANDARDS COMPLIANCE

Meets or exceeds all applicable standards: IEEE 802.3 and 802.3u. Network protocols: TCP/IP, DHCP, ICMP, DNS, NAT, TFTP, HTTP, PPPoE. FCC Part 15 (class B). UPnP requires Windows ME, XP or later.

PHYSICAL SPECIFICATIONS

LAN Interface: 4-port 10/100Mbps RJ-45 Connectors
WAN Interface: 1-port RJ-45 Connector for DSL/Cable Modem Connection.
Reset Button: Resets to factory default settings.
LED Indicators: 1 power indicator, one diagnostic indicator, five Link/Activity, five FDX/Col and five 10/100Mbps indicators.
Security: NAT Firewall. Password-protected configuration.
Management: WEB GUI Configuration
Dimensions: 2.5"H x 6.5"W x 3.27"D
Power: 12VDC @ 1000 mA

DESIGN CONSIDERATIONS

- Connects to a Category 5e Voice and Data Module with Category 5 or Category 5e patch cords.
- Uplink port allows cascading of additional hubs or switches for up to 253 network connections.
- Features LEDs to indicate power, diagnostic, LINK/Activity, FDX/Col and 10/100Mbps.
- Allows multiple users to securely share a single, protected high-speed internet connection.
- Built-in NAT firewall protects networks from outside observation and provides secure communication for network users.
- Customizes web access and filters unwanted sites with URL blocking feature.
- UPnP (universal plug-and-play) allows automatic discovery and configuration of the Gateway. UPnP supported by Windows ME, XP or later.

WARRANTY INFORMATION

- Two-year limited product warranty.

See ELECTRONIC FILES for CAD files (.DXF, .DWG, MS-DOS.EPS) on disk



For ELECTRONIC Typical Specs see (.TXT) file on disk.

TYPICAL SPECIFICATIONS

The 10/100Mbps 4-Port Internet Gateway shall meet all applicable standards: IEEE 802.3 and 802.3u, and FCC part 15 (Class B) compliant. It shall allow multiple users to use a single, secure, high-speed broadband Internet connection (DSL and cable) and contain four RJ-45 ports for LAN application and one RJ-45 port for WAN application. It shall have a NAT Firewall and Password Protection. The Internet Gateway shall have WEB GUI Configuration for management and use TCP/IP, NAT, DHCP, ICMP, DNS, TFTP, HTTP protocols. It shall include a URL blocking feature and universal plug-and-play configuration supported by Windows ME, XP or later.



For Technical Support Call 1-425-485-4288; in USA call 1-800-824-3005
Spec sheets and updates are also available at www.levitonvoicedata.com.

2222 - 222nd St. SE • Bothell, WA 98021 USA
Tel: 1-800-722-2082 / 1-425-485-4288 • Fax: 1-425-483-5270 • Int'l Fax: 1-425-485-9170 • GSA Schedule Available



10/100Mbps 4-Port Internet Gateway

Part Numbers
47611-GT4

DIMENSIONAL LINE ART

See ELECTRONIC FILES for CAD images
(.DXF, .DWG, MS-DOS.EPS)

Back Panel View

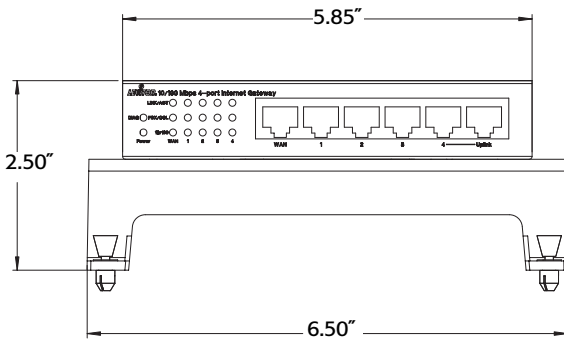

Side Panel View

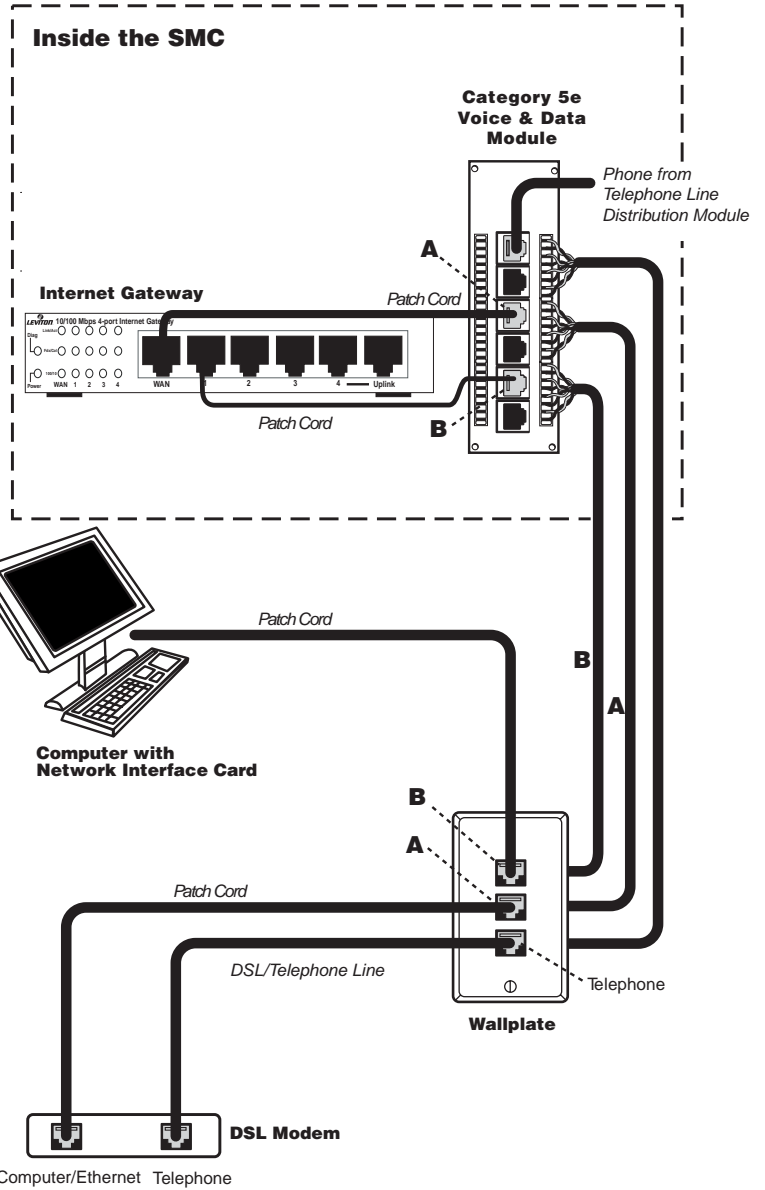
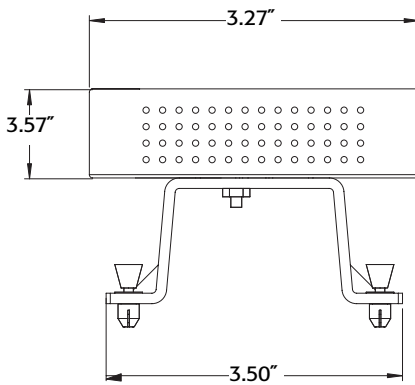

PART NUMBER

Description	Part No.
10/100Mbps 4-Port Internet Gateway	47611-GT4



For Technical Support Call 1-425-485-4288; in USA call 1-800-824-3005.
Spec sheets and updates are also available at www.levitonvoicedata.com.

2222 - 222nd St. SE • Bothell, WA 98021 USA
Tel: 1-800-722-2082 / 1-425-485-4288 • Fax: 1-425-483-5270 • Int'l Fax: 1-425-485-9170 • GSA Schedule Available

