

# 1. INTRODUCTION

The WT-301 is a miniature, wireless, magnetic contact transmitter which can be employed in virtually all applications where an ordinary magnetic contact is normally used.

The WT-301 can be installed on doors, windows and other openings. It can also be flush mounted onto wood or PVC window frames and other surfaces.

Thanks to its slimness and low profile design, the WT-301 can also be completely concealed within the cavity of some PVC window frames.

The opening of a door, window, etc. will trigger the WT-301 into operation, transmitting for approximately 2 seconds to the receiver.

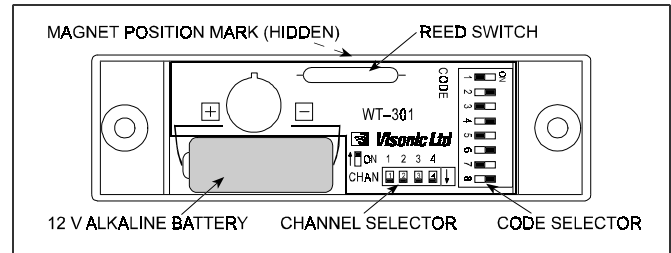

Figure 1. WT-301 - Internal View

# 2. SPECIFICATIONS

**Encoding:** 8-bit - 256 combinations, pulse width modulation.

**Channels:** 4 channels - switch selectable.

**Frequency (MHz):** 315, 404, 418 and 433.92 or other frequencies according to local requirements.

**Transmission Time:** Approximately 2 seconds.

**Power Supply:** 12 Volt alkaline battery (Duracell MN-21, Golden power GP-23A or equivalent).

**Note:** Transmitter characteristics may be affected by battery condition.

**Operating Temperatures:** 0° to 49°C (32° to 120°F).

**Dimensions:** 87 x 25.5 x 15 mm (3.4 x 1.0 x 0.57 in.).

**Weight (excluding battery):** 25.5 g (0.8 oz).

**Color:** White.

**Compliance with Standards:**

Meets the requirements of FCC Part 15, MPT1340, ETS300 220, ETS 300 339 and ETS 300 683.

The 418 and 433.92 models of this device comply with the European Council Directive EMC 89/336/EEC & 92/31/EEC and bear the CE mark and certification.

# 3. INSTALLATION

## 3.1 Coding

A. The WT-301 has an eight-key DIP switch (marked 1 to 8). Each switch may be set to ON or OFF position, to create a unique digital system code - see Figures 1 and 2.

B. Use a ball point pen to set each of the switches to match the code setting of the companion receiver. All wireless PIR detectors, transmitters and the receiver in the system must be set to the same digital code.

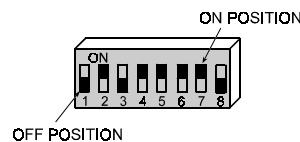

Figure 2. Code Selector

**CAUTION:** The code combination 2, 4, 5, 6, 7 ON - 1, 3, 8 OFF is a factory test code and must not be used. Also avoid codes which are often used: all keys ON, all keys OFF or alternating ON-OFF settings.

## 3.2 Channel Selection

The WT-301 is a multi-channel transmitter. Each transmitter can be set (using the channel selector) to transmit one of the four different messages (channels) on the same system code, to activate different outputs at the receiver.

This feature is very useful for zoning purposes, activating instant and delayed zones at the control panel, etc. The channel selector consists of a 4 key DIP-switch marked "CHAN".

The channel on which the WT-301 will transmit is selected by switching the corresponding channel key to "ON" (fig. 3). Use a ball point pen to set the channel selector.

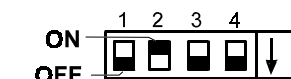

Figure 3. Selecting Channel 2

## 3.3 Battery Installation

The WT-301 is powered by a 12 Volt Alkaline battery (Duracell MN-21, Golden Power GP23A or equivalent).

The battery should be inserted between the two battery clips so that the (+) and (-) markings on the battery are in the same direction as the markings on the P.C. board (close to each battery clip). Check that the battery is held securely by the battery clips.

Separate magnet and transmitter. Verify that the WT-301 activates the receiver output.

**IMPORTANT:** The WT-301 does not include a built-in battery test or supervision capabilities. It is therefore required that the operation of the WT-301 be tested at least once a week.

Although the Alkaline batteries mentioned above should last more than 24 months (in standby), a battery change is recommended at 12 month intervals. If the WT-301 is triggered more than 5 times per day, it may be necessary to change the battery more frequently.

## 3.4 Mounting

**A. Surface mounting (see Figure 4):**

Install the transmitter and magnet as shown. Be careful to install the magnet not more than 6 mm (0.25 in.) from the "marked" side of the transmitter.

**Note:** Transmitter and magnet positions, relative to each other, offer a broad range of installation possibilities.

**B. Flush mounting (see Figure 5)**

1. Prepare an opening for the transmitter: 65x25.5mm (2.56x1")
2. Install the transmitter into the prepared opening.
3. Place the inner cover on the transmitter.

4. Secure the transmitter in place with two screws.
5. Snap the outer cover onto the transmitter assembly.
6. Install the magnet. Make certain that the magnet is positioned next to the marked side of the transmitter case and not more than 6 mm (0.25 in) from it.

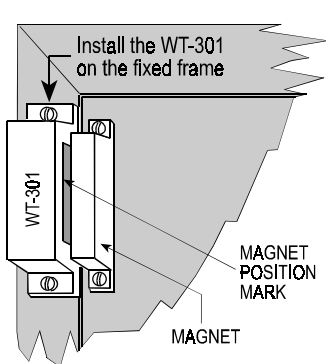

Figure 4. Surface Mounting

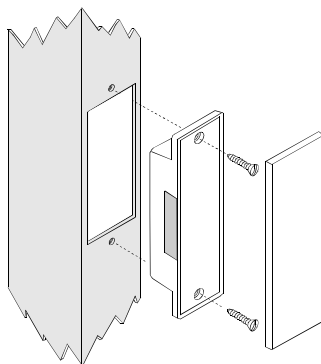

Figure 5. Flush Mounting

### C. Concealed Installation

**Notes:** Because conditions may vary, the following are presented as basic, general instructions:

- Not all window frames are suitable for concealed installation. The most suitable are PVC and wooden frames.
- **DO NOT** install inside metal windows.

1. Prepare the cavity for transmitter installation.
2. Install the transmitter.
3. Install the magnet. Make certain that the magnet is installed next to the marked side of the transmitter case and not more than 6 mm (0.25 in.) from it.

### 3.5 Testing

- A. Activate the transmitter by separating the transmitter and magnet (open door, slide window etc.)
- B. Verify that the WT-301 activates the channel output relay(s) at the receiver which corresponds to the setting of the WT-301 'CHAN' switch(es).

## 4. PRODUCT LIMITATIONS

**NOTES:** Visonic Ltd.'s wireless systems are very reliable and are tested to high standards. However, due to their low transmitting power (required by FCC regulations) there are some limitations to be considered.

- A. Receivers may be blocked by radio signals occurring on or near their operating frequencies regardless of the code selected.
- B. A receiver can only respond to one transmitter signal at a time.

- C. Wireless equipment should be tested regularly (at least once a week) to determine if there are sources of interference and to protect against faults.

**D. Warning:** Changes or modifications to this unit not expressly approved by the party responsible for compliance could void the user's authority to operate the equipment.

### WARRANTY

Visonic Ltd. and/or its subsidiaries and its affiliates ("the Manufacturer") warrants its products hereinafter referred to as "the Product" or "Products" to be in conformance with its own plans and specifications and to be free of defects in materials and workmanship under normal use and service for a period of twelve months from the date of shipment by the Manufacturer. The Manufacturer's obligations shall be limited within the warranty period, at its option, to repair or replace the product or any part thereof. The Manufacturer shall not be responsible for dismantling and/or reinstallation charges. To exercise the warranty the product must be returned to the Manufacturer freight prepaid and insured.

**This warranty does not apply in the following cases:** improper installation, misuse, failure to follow installation and operating instructions, alteration, abuse, accident or tampering, and repair by anyone other than the Manufacturer.

This warranty is exclusive and expressly in lieu of all other warranties, obligations or liabilities, whether written, oral, express or implied, including any warranty of merchantability or fitness for a particular purpose, or otherwise. In no case shall the Manufacturer be liable to anyone for any consequential or incidental damages for breach of this warranty or any other warranties whatsoever, as aforesaid.

This warranty shall not be modified, varied or extended, and the Manufacturer does not authorize any person to act on its behalf in the modification, variation or extension of this warranty. This warranty shall apply to the Product only. All products, accessories or attachments of others used in conjunction with the Product, including batteries, shall be covered solely by their own warranty, if any. The Manufacturer shall not be liable for any damage or loss whatsoever, whether directly, indirectly, incidentally, consequentially or otherwise, caused by the malfunction of the Product due to products, accessories, or attachments of others, including batteries, used in conjunction with the Products.

The Manufacturer does not represent that its Product may not be compromised and/or circumvented, or that the Product will prevent any death, personal and/or bodily injury and/or damage to property resulting from burglary, robbery, fire or otherwise, or that the Product will in all cases provide adequate warning or protection. User understands that a properly installed and maintained alarm may only reduce the risk of events such as burglary, robbery, and fire without warning, but it is not insurance or a guarantee that such will not occur or that there will be no death, personal damage and/or damage to property as a result.

**The Manufacturer shall have no liability for any death, personal and/or bodily injury and/or damage to property or other loss whether direct, indirect, incidental, consequential or otherwise, based on a claim that the Product failed to function.** However, if the Manufacturer is held liable, whether directly or indirectly, for any loss or damage arising under this limited warranty or otherwise, regardless of cause or origin, the Manufacturer's maximum liability shall not in any case exceed the purchase price of the Product, which shall be fixed as liquidated damages and not as a penalty, and shall be the complete and exclusive remedy against the Manufacturer.

**Warning:** The user should follow the installation and operation instructions and among other things test the Product and the whole system at least once a week. For various reasons, including, but not limited to, changes in environmental conditions, electric or electronic disruptions and tampering, the Product may not perform as expected. The user is advised to take all necessary precautions to be his /her safety and the protection of his/her property.