

1. INTRODUCTION

The K-940MCW is a pet-immune, fully supervised ultra low-current wireless PIR that incorporates a PowerCode transmitter. Both transmitter and detector circuits are powered by an on-board, long life 3.6 V Lithium battery.

As a pet immune motion detector, the K-940MCW utilizes TSI™ (Target Specific Imaging) technology that ensures immunity to pets weighing up to 18 kg (40 lb).

As a supervised wireless detector, the K-940MCW has a 24-bit ID code, randomly selected in the factory from over 16 million possible combinations. This code is therefore unique and virtually impossible to reproduce. Compatible PowerCode receivers are designed to "learn" specific IDs and respond only to them.

Following detection of a human intruder, the K-940MCW triggers the on-board transmitter which transmits its specific PowerCode ID followed by an alarm signal and status designators for tampering and battery condition. Alarm and other data are thus forwarded to the alarm control panel or to a head-end computer, depending on the type of system in which the detector is used.

Since messages transmitted by the K-940MCW might collide with messages transmitted by other PowerCode transmitters, an anti-collision transmission sequence is used.

A periodic test transmission for supervision purposes takes place automatically once an hour. The receiver is thus informed

that the particular detector is taking an active part in the wireless network.

After triggering the transmitter, the K-940MCW inhibits itself to save battery power. The detector rearms itself automatically (reverts to the ready state) 2 minutes after the last movement has been detected. An LED/ WALK-TEST jumper is used to override the 2-minute rearm timer during walk testing.

A programmable pulse counter is included in the unit for maximum immunity against false alarms.

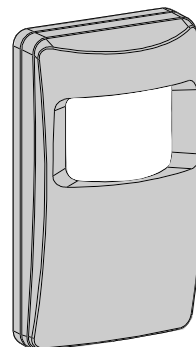

Figure 1. General View

2. SPECIFICATIONS

OPTICAL

Max. Coverage Range: 9 x 9 m (30 x 30 ft) / 90°

Pet Immunity: Animals weighing up to 18 kg (40 lb).

Vertical Adjustment: 3-position adjustment scale: 1.8 m (6 ft), 2.1 m (7 ft) and 2.4 m (8 ft).

ELECTRICAL

Battery Type: 3.6 Volt lithium thionyl chloride (LiSOCl₂) battery, size 1/2AA, Tadiran TL-5902 or equivalent.

Nominal Battery Capacity: 1.2 Ah

Standby Current Drain: 0.015 mA.

Transmit Current Drain: 9.5 mA (including LED)

Battery Life (with LED on)

@ 10 transmissions per day: about 7 years

@ 50 transmissions per day: about 5 years

LED: Lights for 2 seconds upon transmission and upon motion detection in the walk test mode.

Detector: Dual-element low-noise pyroelectric sensor.

Pulse Counter: Programmable to 1, 3 or 5 pulses.

Rearm Timer: 2 minutes after the last alarm; timer disabled in the walk test mode.

WIRELESS

Frequency (MHz): 315, 404, 418, 433.92 or other frequencies according to local requirements.

Transmission Sequence: 3 data bursts at variable intervals within 3 seconds.

Encoding: 24-bit factory selected ID code, over 16 million possible combinations.

Total Message Length: 36 bits

Battery Supervision: Automatic reporting of low-battery status with each alarm and with periodic autotest.

Tamper Alert: Reported at 3-minute intervals, until the tamper switch is restored.

ENVIRONMENTAL

Operating Temperature: -10° to 50°C (14° to 122°F).

Storage Temperature: -20° to 60°C (-4°F to 140°F).

RFI Protection: > 20 V/m up to 1000 MHz.

PHYSICAL

Weight: 71 g (2.5 oz).

Dimensions (H x W x D): 104 x 60 x 32 mm (4.1 x 2.4 x 1.3 in.)

Color: White.

Compliance with Standards: FCC Part 15, ETS300-220 and MPT1349

OPTIONAL MOUNTING ACCESSORIES

BR-1: Swivel bracket for wall mounting.

BR-2: BR-1 + corner mounting adapter.

BR-3: BR-1 + ceiling mounting adapter.

3. INSTALLATION

Since this is a PowerCode type transmitter, it is recommended to power it up and let the target receiver "learn" the transmitter's ID before actual installation.

3.1 Battery Insertion

A. Insert the battery into the battery clip - observe polarity (see Figure 2).

B. Press the tamper switch lever once and release it. This will perform the reset necessary for smooth power up.

C. Put the cover on and watch the LED. It will flash once in 2 seconds for at least 15 seconds until the sensor stabilizes.

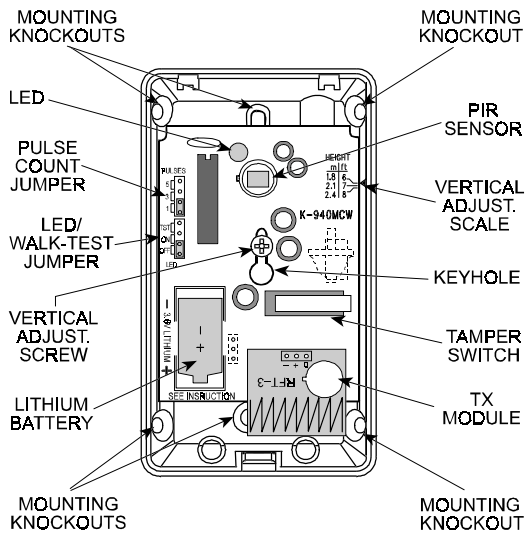

Figure 2. Components Layout

3.2 Enrolling the Transmitter ID in the Target Receiver's Memory

Refer to the target receiver's installation instructions and follow the procedure given there for "teaching" transmitter IDs. It is much easier to carry out this operation in close proximity to the receiver.

3.3 Selecting the Mounting Location

The K-940MCW can be mounted directly onto the wall (surface mounted), or in a corner, using the mounting knockouts. Always mount the unit on a firm and stable surface. Optional swivel brackets permit greater flexibility when directing the detector at a desired point (Para. 3.8).

- Select the mounting location so that an intruder's motion will cross the detector's coverage area.
- You may mount the unit at the height of 1.8 m (6 ft), or 2.1 m (7 ft), or 2.4 m (8 ft).

Important! The detector is immune to 18 kg (40 lb) animals moving on the floor or climbing on furniture as long as the activity takes place below 1 m (3 ft). Above the 1 m (3 ft) height limit, the detector is immune to 9 kg (20 lb) pets, but the pet immunity will decrease as the pet gets closer to the detector. It is therefore recommended to select a mounting location that minimizes potential close proximity of animals.

- To minimize false alarms, avoid aiming the detector at heaters, sources of bright light, or windows subjected to direct sunlight.
- The PIR detector senses the difference between the infrared energy transmitted by a moving body and the background temperature. It is therefore recommended that the PIR be aimed toward the coolest place in the protected area, in order to obtain the maximum sensitivity in installations where high background temperatures are expected.

3.4 Direct Mounting

- Loosen and remove the screw at the bottom of the case and take the cover off.
- Punch out the appropriate mounting knockouts in the base.

Note: For wall surface mounting, use the two elongated knockouts at the middle of the base. For corner mounting, use two diagonally opposite knockouts at the angled sides of the base (see Figure 2).
- Loosen the vertical adjustment screw, slide the printed circuit board upward and remove it via the "keyhole".
- Use the base as a template for marking the drilling points.
- Drill mounting holes and insert masonry anchors if required.
- Mount the base in place using two screws.

- Remount the PCB and secure it with the vertical adjustment screw.

3.5 Vertical Adjustment

A. Pet-Immune Applications

To maintain maximum coverage range and pet immunity, the vertical adjustment scale must be adjusted in accordance with the actual mounting height (refer to Figure 3). Loosen the vertical adjustment screw and slide the printed circuit board up or down until the pointer shows the actual mounting height on the scale. When done, re-tighten the screw well.

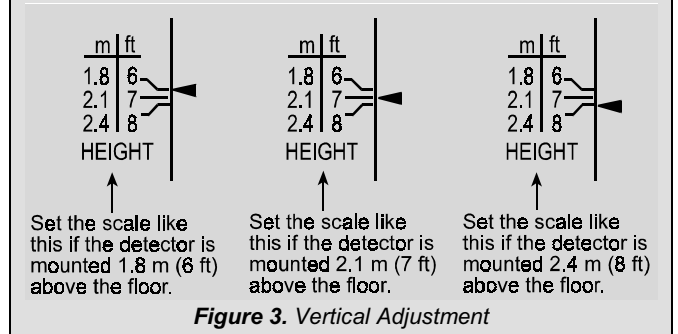

Figure 3. Vertical Adjustment

B. Pet-Free Locations

To obtain the best coverage possible where no pets are present, mount the detector with a swivel bracket (see Para. 3.8) at any desired height between 1.8 m (6 ft) and 2.4 m (8 ft). Then set the vertical adjustment scale **to the 2.4 m (8 ft) position** and use the bracket to tilt the detector 30° down.

3.6 Setting the Pulse Counter

K-940MCW detectors are equipped with a programmable pulse counter which can be set to count 1, 3 or 5 pulses, before activating the wireless transmitter. Place the pulse count jumper at the desired setting (1, 3 or 5 - see Figure 4).

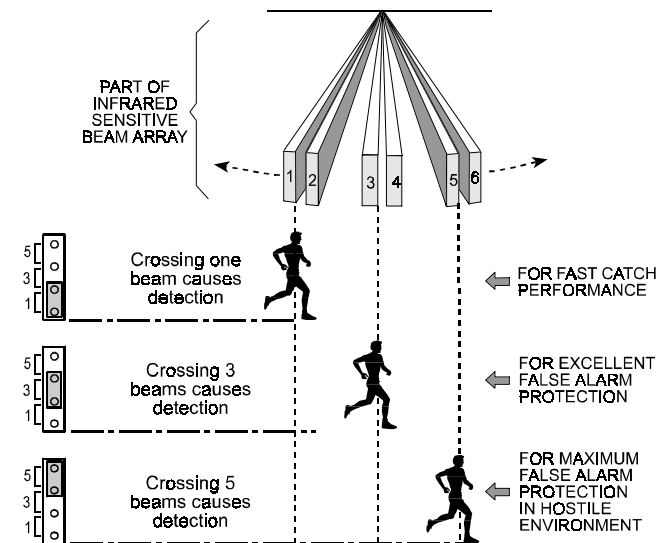

Figure 4. Setting the Pulse Counter

3.7 Walk Testing

IMPORTANT! The range and the coverage area of the unit should be checked at least once a year. To assure proper continuous functioning, the end user should be instructed to perform a walk test at the far end of the coverage pattern prior to each time the alarm system is armed.

To save battery power in normal use, an automatic timer inhibits the detector for approximately 2 minutes after transmitter activation. The detector is automatically rearmed 2 minutes after detection of the last motion.

For effective walk testing, it is necessary to override the 2 minute timer by setting the LED/WALK-TEST jumper to the TEST position as shown to the right. →

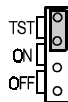

Remember that in this mode, the supervision test message will be transmitted at 1 minute intervals instead of 1 hour intervals.

IMPORTANT! Once the cover is replaced, the detector goes through a stabilization period. The LED will flash once per 2 seconds until the detector has stabilized (stabilization time is at least 15 seconds).

A. Walk-test the entire protected area by walking slowly across the detector's field of view, observing the LED. Pause for 5 seconds after each test to allow the unit to complete its 3-transmission sequence (see Appendix A); the LED will light for 2 seconds.

B. Set the LED/WALK-TEST jumper to the ON position as shown to the right. →

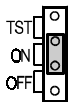

Wait outside the coverage area. After five minutes, re-enter the coverage area and verify that the LED lights for 2 seconds upon detection.

C. If you continue moving, the unit will remain disabled due to the 2-minute battery saving timer. The unit will be rearmed provided that no motion is detected for approximately 2 minutes, and will then be ready to detect and transmit.

D. When done, set the LED/WALK-TEST jumper to the OFF position as shown to the right. →



This setting is recommended to prevent unauthorized people from tracing the detector's coverage pattern.

3.8 Mounting with Swivel Brackets (optional)

The BR-1 is a swivel, surface-mount bracket which provides greater flexibility when choosing the direction at which the

detector is pointed. The BR-1 is adjustable 30° downward and 45° left or right (Fig. 5).

The BR-2 is a similar swivel bracket kit for room corners.

The BR-3 is a similar swivel bracket kit for ceilings.

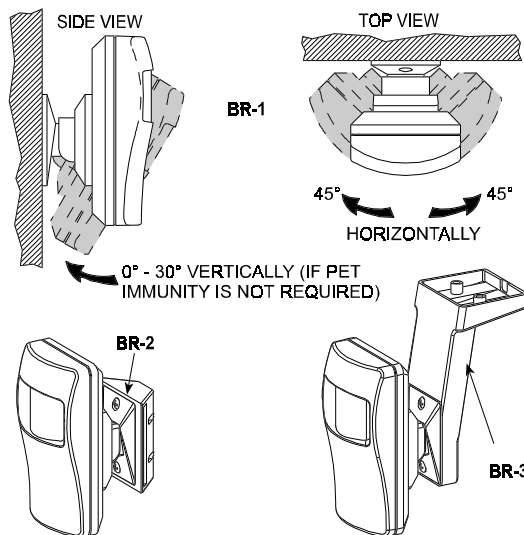
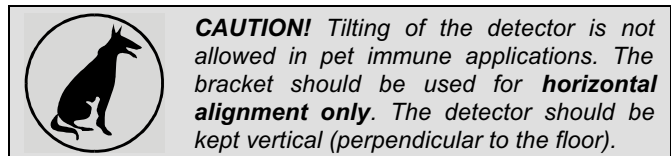

Figure 5. Optional Swivel Brackets

4. NOTES AND WARNINGS

4.1 Product Limitations

Visonic Ltd. wireless systems are reliable and are tested to high standards. However, due to the low transmitting power (required by the FCC and other regulating authorities), there are some limitations to be considered:

- A.** A receiver may be blocked by radio signals sent on or near its operating frequency, regardless of the digital code used.
- B.** A receiver responds to one transmitted signal at a time.
- C.** Wireless equipment should be tested regularly (at least once a week) to discover sources of interference and to protect against faults.

4.2 Compliance with Standards

This device complies with FCC Rules Part 15. Operation is subject to two conditions: (1) This device may not cause harmful interference, and (2) this device must accept any interference that may be received or that may cause undesired operation.

WARNING! Changes or modifications to this unit not expressly approved by the party responsible for compliance could void the user's authority to operate the equipment.

This device complies with the European Council Directive EMC 89/336/EEC & 92/31/EEC and bears the CE mark and certification.

APPENDIX A. THE VISONIC LTD. POWERCODE SYSTEM

A-1. The PowerCode Message Format

The PowerCode message transmitted by the K940MCW includes the detector's 24-bit ID and a status report (see Fig. A1).

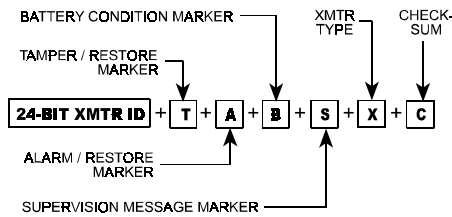

Figure A1. Transmitted Data

A message includes the following data:

- **Detector's ID:** Any message transmitted starts with the 24-bit ID assigned to the particular detector unit.
- **Tamper / Restore:** Upon removal of the unit's front cover, a message will be transmitted with a "tamper marker" ON. If the unit's cover is put back, a message will be transmitted with the tamper marker OFF ("Tamper Restore").
- **Alarm:** Once the detector is in alarm, a message will be transmitted with an "alarm marker" ON.
- **Low Battery:** A special battery condition marker is used to report the battery status in any message. The battery is tested once an hour and if found low, the "low battery marker" is set to ON in all following messages.
- **Supervision Message:** A special "supervision message marker", when set to ON, identifies the periodic supervision

messages transmitted automatically at 1 hour intervals. This marker will be OFF in all other messages.

- **Transmitter Type:** A special marker indicates the type of the transmitter:
 - Supervised or non-supervised
 - Reports or does not report restorals after alarm
 The K-940MCW does not reports restorals after alarms.
- **Checksum:** Checksum bits at the end of the message allow the receiver to determine whether an incoming message is valid (error-free). This feature considerably upgrades the reliability of the wireless communication link.

A-2. Anti-Collision

To overcome message collisions at the receiving end, PowerCode transmitters transmit 3 data bursts at random intervals, with 6 repetitions of the same message in each burst (Fig. A2). This redundancy improves the probability of reception.

Note: Periodic supervision messages are an exception to this rule - they consist of a single 6-message burst.

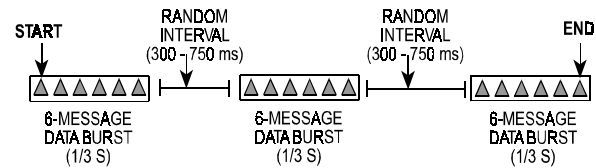

Figure A2. Anti-Collision Transmission Sequence

WARRANTY

Visonic Ltd. and/or its subsidiaries and its affiliates ("the Manufacturer") warrants its products hereinafter referred to as "the Product" or "Products" to be in conformance with its own plans and specifications and to be free of defects in materials and workmanship under normal use and service for a period of twelve months from the date of shipment by the Manufacturer. The Manufacturer's obligations shall be limited within the warranty period, at its option, to repair or replace the product or any part thereof. The Manufacturer shall not be responsible for dismantling and/or reinstallation charges. To exercise the warranty the product must be returned to the Manufacturer freight prepaid and insured.

This warranty does not apply in the following cases: improper installation, misuse, failure to follow installation and operating instructions, alteration, abuse, accident or tampering, and repair by anyone other than the Manufacturer.

This warranty is exclusive and expressly in lieu of all other warranties, obligations or liabilities, whether written, oral, express or implied, including any warranty of merchantability or fitness for a particular purpose, or otherwise. In no case shall the Manufacturer be liable to anyone for any consequential or incidental damages for breach of this warranty or any other warranties whatsoever, as aforesaid.

This warranty shall not be modified, varied or extended, and the Manufacturer does not authorize any person to act on its behalf in the modification, variation or extension of this warranty. This warranty shall apply to the Product only. All products, accessories or attachments of others used in conjunction with the Product, including batteries, shall be covered solely by their own warranty, if any. The Manufacturer shall not be liable for any damage or loss whatsoever, whether directly, indirectly, incidentally, consequentially or otherwise, caused by the malfunction of the Product due to products, accessories, or attachments of others, including batteries, used in conjunction with the Products.

The Manufacturer does not represent that its Product may not be compromised and/or circumvented, or that the Product will prevent any death, personal and/or bodily injury and/or damage to property resulting from burglary, robbery, fire or otherwise, or that the Product will in all cases provide adequate warning or protection. User understands that a properly installed and maintained alarm may only reduce the risk of events such as burglary, robbery, and fire without warning, but it is not insurance or a guarantee that such will not occur or that there will be no death, personal damage and/or damage to property as a result.

The Manufacturer shall have no liability for any death, personal and/or bodily injury and/or damage to property or other loss whether direct, indirect, incidental, consequential or otherwise, based on a claim that the Product failed to function. However, if the Manufacturer is held liable, whether directly or indirectly, for any loss or damage arising under this limited warranty or otherwise, regardless of cause or origin, the Manufacturer's maximum liability shall not in any case exceed the purchase price of the Product, which shall be fixed as liquidated damages and not as a penalty, and shall be the complete and exclusive remedy against the Manufacturer.

Warning: The user should follow the installation and operation instructions and among other things test the Product and the whole system at least once a week. For various reasons, including, but not limited to, changes in environmental conditions, electric or electronic disruptions and tampering, the Product may not perform as expected. The user is advised to take all necessary precautions for his/her safety and the protection of his/her property.

6/91



VISONIC LTD (ISRAEL): P.O.B 22020 TEL-AVIV 61220 ISRAEL. PHONE: (972-3) 645-6789, FAX: (972-3) 645-6788
 VISONIC INC. (U.S.A.): 10 NORTHWOOD DRIVE, BLOOMFIELD CT. 06002-1911. PHONE: (860) 243-0833, (800) 223-0020 FAX: (860) 242-8094
 VISONIC LTD. (UK): UNIT 1, STRATTON PARK, DUNTON LANE BIGGLESWADE, BEDS. SG 18 8QS. PHONE: (01767) 600857 FAX: (01767) 601098
 INTERNET: www.visonic.com

©VISONIC LTD. 1998 K-940MCW DE3635- (REV. 0, 7/98)



MADE IN ISRAEL