

# SOLAR II IN ONE BATTERY CHARGER WITH METER

**Model No. ES879**

U.K. Patent No. 2058658  
USA Patent No. D400, 163  
Taiwan Patent No. 85307563  
PRC China Patent No. 96308835.1

## How to use

1. Open the transparent cover .
  2. Correctly place 2 pieces rechargeable batteries (Either 'D', 'C', 'AA', 'AAA' size or GUM batteries) in the battery compartment (FIG 1)
  3. To avoid those 'AA' and 'AAA' size battery bounced, upright the spring ring vertically, then insert the battery through the ring; small ring for 'AAA' battery and larger ring for 'AA' battery (FIG 2)
  4. To charge C size, AA size, AAA size and GUM battery (prismatic battery ), slightly pull back the vertical metal connector horizontally in order to place the battery easily (FIG 3)
  5. To charge GUM battery, slide up or down the Adjustable Metal Connector (W SHAPE) for different thickness battery.(FIG 4)  
Check and scan the meter needle pin, it should indicate a certain level when there is bright sunlight.
  6. If the meter needle pin stayed in zero position, it means open circuit, then adjust the 'W' shape connector by slide up or down to make a good contact position. After that, the needle pin will move up immediately in a good condition.  
As most of us know by experience, the resistance is different between different sizes of batteries. Even if they are the same size different brand of batteries will has different resistance. So the charger is designed to charge 2 pieces of the same size and same brand batteries only.Do not attempt to mix different sizes and different brand rechargeable batteries or charge more than 2 pcs batteries simultaneously.  
Close the transparent cover.
  7. Adjust the angle stand at the bottom of the charger in order to face the sunlight directly. (FIG 5)
  8. Place the charger in bright sunlight or strong artificial light, the more sunlight is received, the more energy will be stored in the battery. (FIG 6)
  9. It is recommended to place the charger on the window sill,balcony, backyard..... Where there is maximum sunlight.
  10. Check and scan the meter's needle pin. It will indicate at 160 mA when there is strong sunlight. If the meter's needle pin points at 80 mA, it means there is less sunlight and will take longer time to be fully charged.
  11. The meter will show you how long does it take to fully charge the battery. For example: to charge 2 pcs D size battery (1500mA), read the first green line from the meter. If the needle pin shows at 160 mA (IN FULL SUN) (FIG 7) then it takes Approx 9 hours for fully charged.
- Note : Recharging time will vary depending upon the strength of the sunlight or the level to which the batteries are discharged.
12. Check the meter needle pin, it should indicate a certain level when there is bright sunlight.
  13. Some of the batteries are same size but there are different capacity current (mA) from different company brand. If the capacity is higher, then charge it longer time. Read the current (mA) column. The time can be calculated as below:

$$\text{eg: Time} = \frac{\text{D-SIZE CAPACITY } 1500 \text{ mA}}{\text{SUN POWER CURRENT } 160 \text{ mA}} = 9 \text{ HOURS}$$

# SOLAR 11 IN ONE BATTERY CHARGER WITH METER

Model No. ES879

U.K. Patent No. 2058658  
USA Patent No. D400, 163  
Taiwan Patent No. 85307563  
PRC China Patent No. 96308835.1

## INSTRUCTIONS:

FIG 1

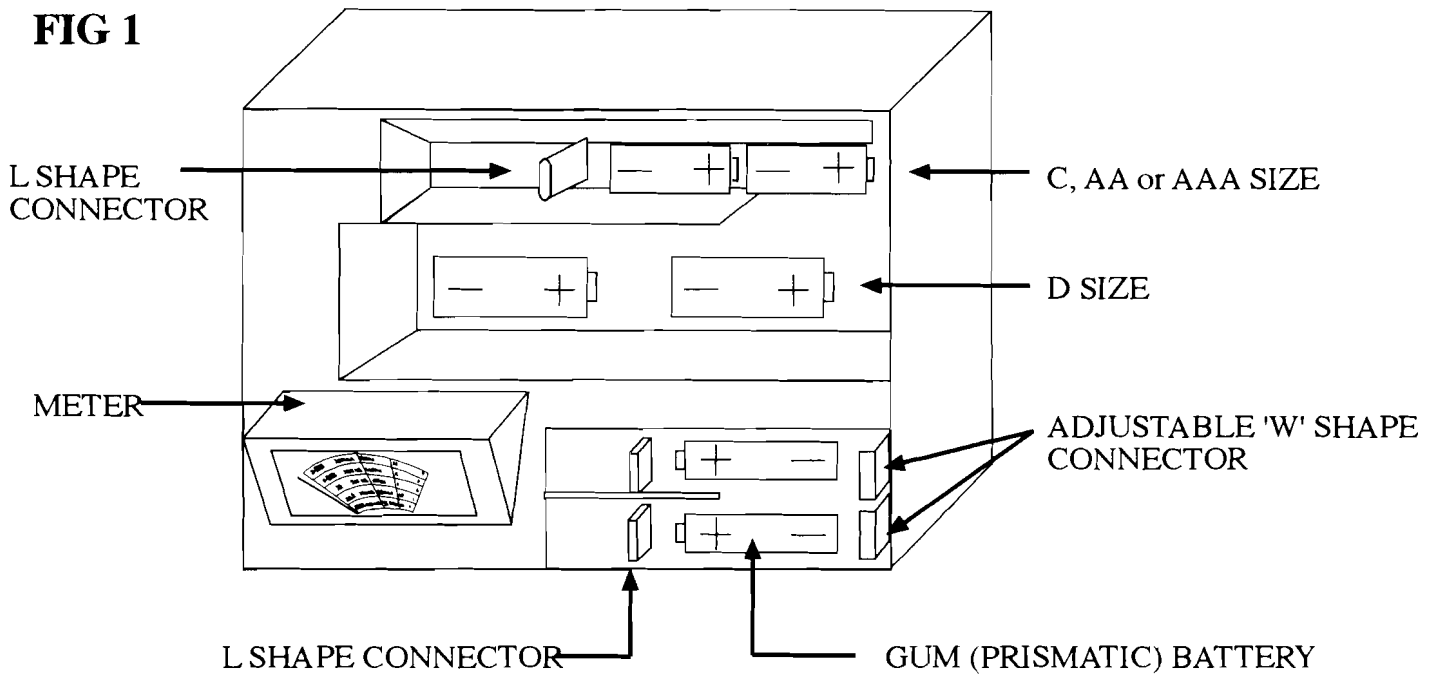

FIG 2

To avoid battery bounced, upright the spring ring vertically, then insert the battery through the ring, small ring for "AAA" battery and large ring for "AA" battery.

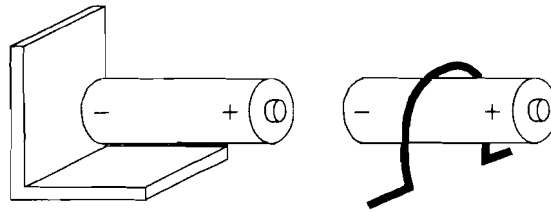
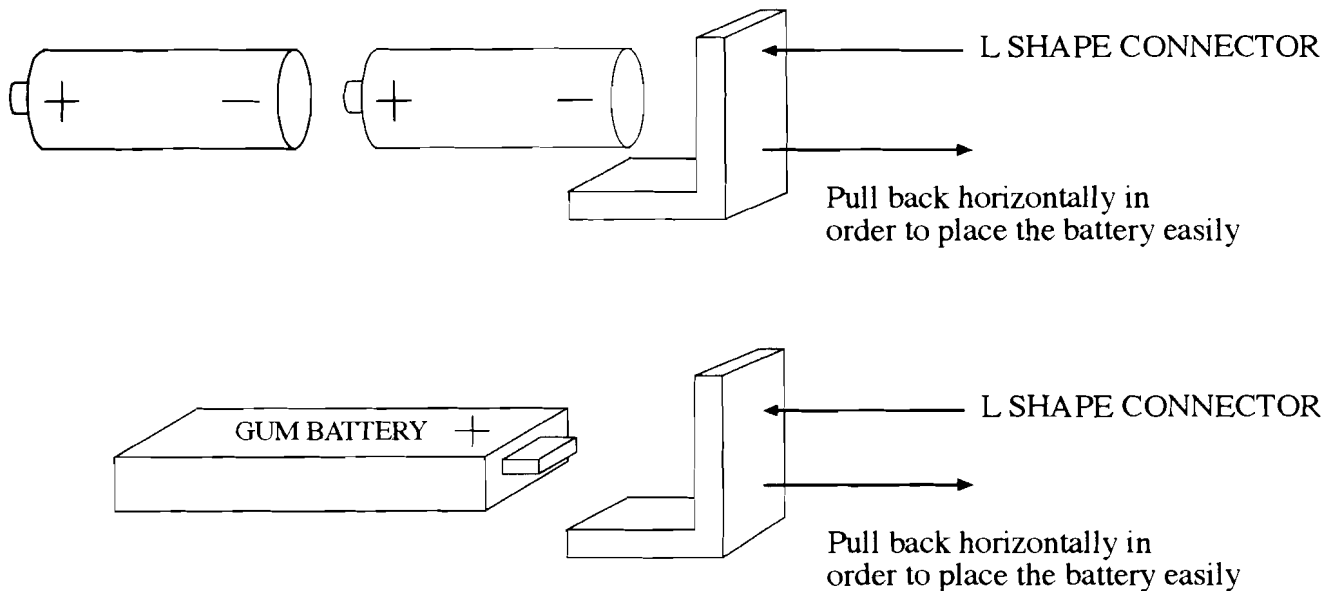
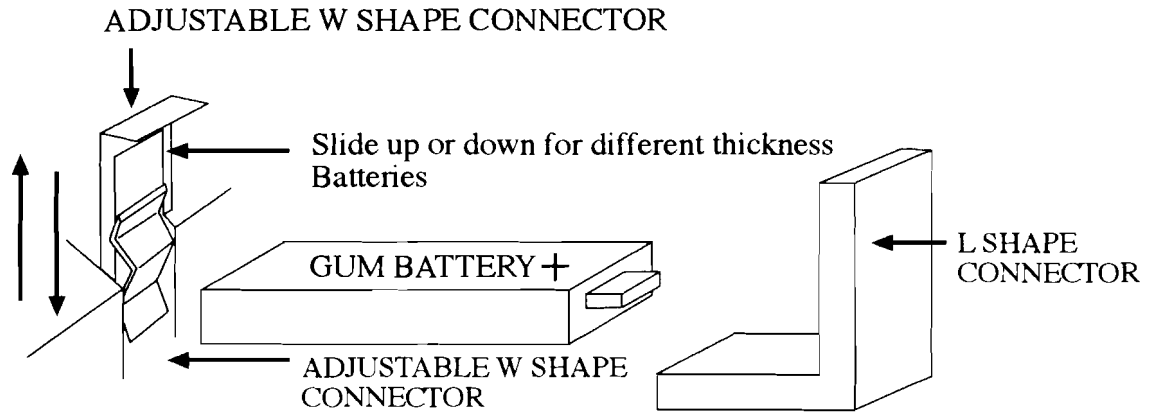

FIG 3

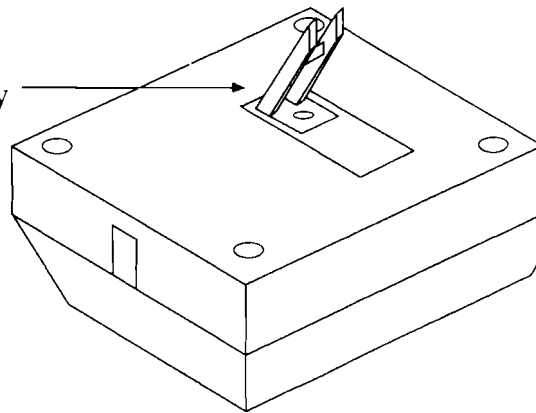

**FIG 4**



**FIG 5**

Pull up the stand angle in order to face sunlight directly



**FIG 6**

Expose the charger where there is maximum sunlight and face the sunlight directly

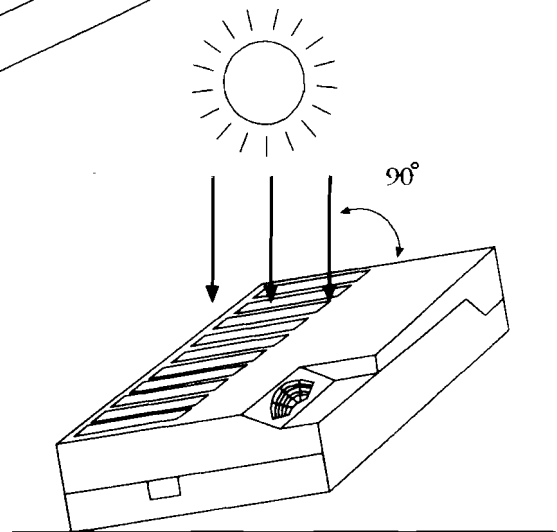

**FIG 7**

