

HOW TO ASSEMBLE

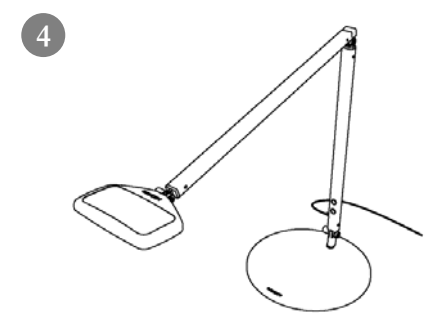
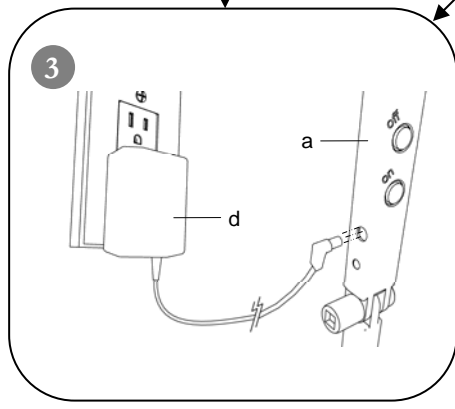
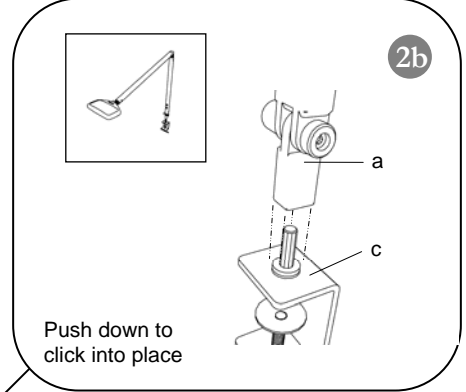
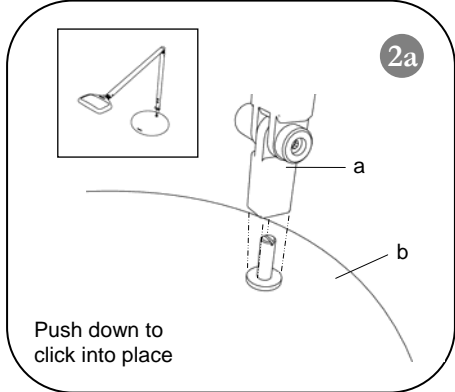
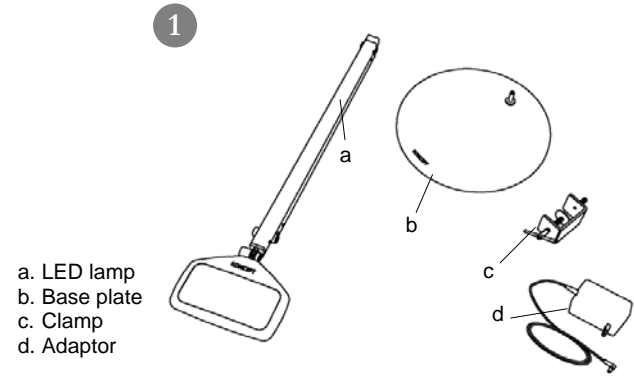

LIMITED PRODUCT WARRANTY

One Year Limited Product Warranty

Koncept Technologies warrants to the original purchaser of this product against manufacturer defects in design, assembly, material, or workmanship, and will, at Koncept's option, replace or repair any defective product free of charge. This coverage is valid for one year from the date of purchase as long as the original purchaser owns the product. Koncept will replace or repair the product, which Koncept, at its sole discretion, agrees is defective, free of charge provided that the following conditions for a return are fulfilled.

This warranty does not apply to any product damaged by accident, physical or electrical misuse or abuse, improper installation, alteration, any use contrary to its intended function, war, fire, flood, or any other acts of nature, or unauthorized repair.

Koncept assumes no liability for any events such as fines arising out of the use of this product or any consequential damages caused by any failure of the product to function properly. Under no circumstances should this warranty or the product covered by it be construed as an insurance policy against loss of any kind. Koncept staff neither assumes nor authorizes any person or organization to make any warranties or assume any liability in connection with the sale or use of this product. This warranty covers only products used in the 50 US states and/or Canada. This is the complete LL2001 warranty and no other warranty exists. Some jurisdictions may not allow limitations on how long an implied warranty lasts, or the exclusion or limitation of incidental or consequential damages, so the above exclusions or limitations may not apply to you. This warranty gives you specific legal rights, and you may also have other rights which vary in different states and countries.

To file a replacement/repair claim under the warranty:

- 1) Contact Koncept for a return authorization number during the warranty period. A claim will not be accepted without a return authorization number.
- 2) Make a copy of the original purchase receipt with purchase date and product name clearly shown.
- 3) Provide original purchaser's full name, email address*, daytime phone, and postal address.
- 4) Return the defective product to Koncept freight prepaid and accompanied by (1), (2), and (3) to the following address:
Limited Product Warranty
Koncept Technologies, Inc.
1111 Corporate Center Dr. #304A
Monterey Park, CA 91754
U.S.A.

*Optional

WARNING: TO REDUCE THE RISK OF FIRE, ELECTRIC SHOCK OR INJURY:

- Do not use outdoors or near water.
- Do not handle plug or appliance with wet hands.
- Do not stare directly at the LEDs.

TO AVOID OVERHEATING

- Keep out of direct sunlight.
- Recommended ambient temperature: under 77° Fahrenheit.

 **REMOVE PLASTIC BAG FROM LED HEAD BEFORE USE. FAILURE TO DO SO MAY RESULT IN OVER-HEATING AND REDUCED LED LIFESPAN.**

 **DO NOT USE AN EXTERNAL DIMMER WITH THIS LAMP. DOING SO MAY CAUSE DAMAGE TO THE PRODUCT.**

SPECIFICATIONS

Model number	LL2001
Power consumption	9.6 W
Color Temperature	6000K ~ 8000K
Light color	White

Contact Information

Koncept Technologies Inc.
1111 Corporate Center Dr. #304A
Monterey Park, CA 91754
U.S.A.
Phone: 323.261.8338
Fax: 323.261.8998

Customer Support: support@koncepttech.com
Web Address: www.koncepttech.com