

Scene Capable Plug-In Appliance Module

Cat. No. RZP15

Incandescent: 1800W Fluorescent: 1800VA Resistive: 15A Motor: 1/2HP
Rated: 120VAC, 60Hz

INSTALLATION INSTRUCTIONS



Compatible with  enabled products!

WARNINGS AND CAUTIONS:

- To be installed and/or used in accordance with appropriate electrical codes and regulations.
- If you are unsure about any part of these instructions, consult a qualified electrician.

WARNINGS AND CAUTIONS:

- Unplug unit when servicing fixture or changing bulbs.
- Save this instruction sheet. It contains important technical data along with testing and troubleshooting information which will be useful after installation is complete.

INTRODUCTION

Leviton's Vizia™ RF components are designed to communicate with each other via Radio Frequency (RF) to provide remote control of your lighting. Using RF technology allows Leviton to provide the greatest signal integrity possible. Each module in Leviton's Vizia™ RF component line is a Z-Wave™ enabled device. In a Z-Wave™ network, each device is designed to act as a router. These routers will re-transmit the RF signal from one device to another until the intended device is reached. This ensures that the signal is received by its intended device by routing the signal around obstacles and radio dead spots. The Scene Capable Plug-in Lamp Dimming Module is compatible with any Z-Wave™ enabled network, regardless of the manufacturer and can also be used with other devices displaying the Z-Wave™ logo.

CAUTION:

Remember to exercise good common sense when using the Timer features of your remote, especially when scheduling unattended devices. There can be some unexpected consequences if not used with care. For example, an empty coffee pot can be remotely turned on. If that should happen, your coffee pot could be damaged from overheating. If an electric heater is turned on by remote control while clothing is draped over it, a fire could result. **DO NOT USE** the remote for the control of high power heating appliances such as portable heaters. This device will not control lighting that is used with electronic low-voltage and high frequency power supply transformers, nor high pressure discharge lamps (HID lighting). This includes mercury-vapor, sodium vapor and metal halide lamps.

FEATURES

- Soft fade ON/OFF
- Scene capable
- ON/OFF LED
- Two way communication
- RF reliability
- Ease of installation – No new wiring
- Compatible with other Z-Wave™ enabled devices

INSTALLING YOUR APPLIANCE MODULE

NOTE: Use check boxes when Steps are completed.

Step 1 Attaching Load to Scene Capable Plug-In Appliance Module:

NOTE: In order to use your Vizia™ Scene Capable Plug-In Appliance Module in a Z-Wave™ network, it must be included in the network using a Primary Programmer/Remote, such as Leviton's Cat. No. RZCPG. Before including your module, please refer to the Primary Programmer/Remote instruction sheet for complete information. **Refer to Step 3 for further details.**

- Locate load to be controlled by Scene Capable Plug-In Appliance Module and ensure it is fully operational. Attach load plug into module receptacle noting proper polarity of blades.



Step 2 Attaching Scene Capable Plug-In Appliance Module to Wall Receptacle:

- Plug the Scene Capable Plug-in Appliance Module into wall receptacle. Verify that receptacle is live. If controlled by a wall switch, the switch **must be kept ON** at all times.

Step 2 cont'd



Step 3 Including Scene Capable Plug-In Appliance Module into Z-Wave™ Network:

NOTES:

- If using a non-Leviton Programmer/Remote, refer to the Programmer/Remote instruction sheet for including a device.
- If using a Leviton Z-Wave™ Programmer/Remote, Cat. No. RZCPG, press the Menu button and scroll down to System Setup. Press the center button to select System Setup Menu. Press the center button to select Network.

Programmer/Remote
Cat. No. RZCPG

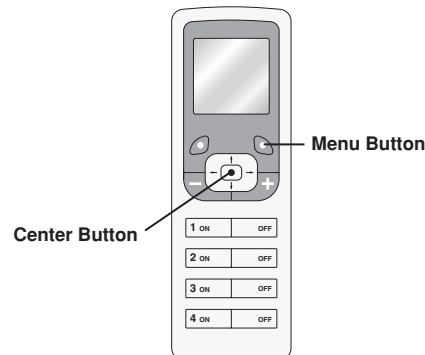

Step 3 cont'd

B) While standing close to the module (approximately 2-5 ft.), press the center button to <Include> device in the network.

NOTE: Only one device may be included at a time. **DO NOT** put multiple devices into the Inclusion mode at any time.

C) While the Programmer/Remote is in the Inclusion mode and the LED is ON on the Scene Capable Plug-In Appliance Module, press the ON/OFF button on the module. The Programmer/Remote will verify inclusion and the LED will turn OFF on the Scene Capable Plug-In Appliance Module.

If the Scene Capable Plug-In Appliance Module is flashing Amber while in the Inclusion mode, the Programmer/Remote is still trying to communicate with the Scene Capable Plug-In Appliance Module. Wait until the device stops flashing, then press ON/OFF button.

NOTE: If the LED on the Scene Capable Plug-In Appliance Module turns solid Red while including, there has been a communication error. **Refer to Troubleshooting section.**

D) The Primary Programmer/Remote will assign a node ID number (Name) for this module.

NOTE: This ID number (Name) will be stored in the controller to be used for future reference.

NOTE: You may name or edit the node of this device at this time.

E) The module is now installed in the network.

NOTE: If the module has been successfully included in the network and the user tries to include it again without first excluding it from the network, the module will retain the first node ID it had received and ignore the second.

Programming and
ON/OFF Button

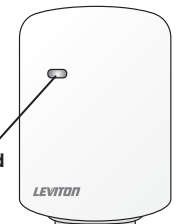

Step 3 cont'd

Including Scene Capable Plug-In Appliance Module into Z-Wave™ Network:

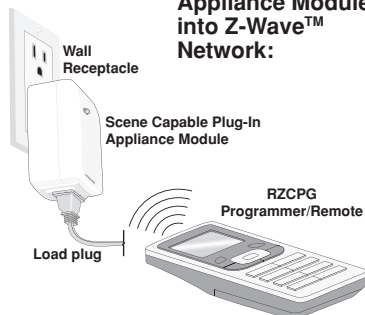

NOTE: Remote must be in close proximity to Scene Capable Plug-In Appliance Module when including in the network.

Step 4 Excluding Scene Capable Plug-In Appliance Module from Network:

NOTE: It is very important to accurately exclude devices from the network when moving or removing a device from a Z-Wave™ network. This ensures that all information has been removed from your Primary Programmer/Remote's information table and is not counted on to be a part of the mesh network.

A) If using a Leviton Z-Wave™ Programmer/Remote, Cat. No. RZCPG, press the Menu button and scroll down to System Setup. Press the center button to select System Setup Menu. Press the center button to select Network.

B) While standing close to the module, press the center button to <Exclude> device from the network.

NOTE: Only one device may be excluded at a time.

C) While the Programmer/Remote is in the Exclusion mode and the LED is ON on the Scene Capable Plug-In Appliance Module, press the ON/OFF button on the module. The Programmer/Remote will verify Exclusion and the LED will turn OFF on the Scene Capable Plug-In Appliance Module.

If the Scene Capable Plug-In Appliance Module is flashing Amber while in the Exclusion mode, the Programmer/Remote is still trying to communicate with the module. Wait until the device stops flashing, then press the ON/OFF button.

Step 4 cont'd

Factory Default:

If your module is not responding, or you are unable to control it after you have tried to Include/Exclude it multiple times, it may be necessary to reset the module to its original factory settings. To accomplish this, proceed as follows:

- Unplug the module and wait 5 seconds. Plug the module back in and within 20 seconds press and hold the programming button until the LED flashes Amber and turns solid Red. The module is now reset. Once the module is reset, it will be necessary to Re-Include it to a network before it can be used.

CAUTION: SETTING A DEVICE TO A FACTORY DEFAULT DOES NOT EXCLUDE THAT DEVICE FROM A NETWORK. THE EXCLUSION PROCEDURE MUST STILL BE FOLLOWED TO REMOVE THE DEVICE FROM THE PRIMARY REMOTE'S INFORMATION TABLE. FAILURE TO DO SO MAY RESULT IN SYSTEM THAT IS SLOW TO RESPOND, OR MAY FAIL TO RESPOND TO SOME DEVICES.

OPERATION

NOTE: For complete details on operating the Primary Programmer/Remote, refer to the individual device's instruction sheet.

ON: Press the ON/OFF button on the Scene Capable Plug-In Appliance Module or appropriate address "ON" button on the applicable transmitter. The Load will turn ON.

OFF: Press the button on the Scene Capable Plug-In Appliance Module or appropriate address "OFF" button on the applicable transmitter. The Load will turn OFF.

MANUAL ON/OFF PRIOR TO INCLUDING IN NETWORK: The Scene Capable Plug-In Appliance Module can control the Load before being included in the Z-Wave™ network.

After powering up the Scene Capable Plug-In Appliance Module, wait 10 seconds then use ON/OFF button to turn the Load ON or OFF.

NOTE: If a power interruption should occur while the module is ON, the light load will return to its previous state when power is restored.

Press ON/OFF Button

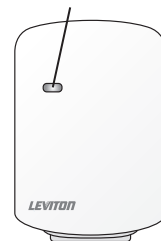

TROUBLESHOOTING

If the Scene Capable Plug-In Appliance Module appears to be functioning improperly, proceed with the following steps:

1. Confirm that the device is being supplied from a 120V, 60Hz AC source ONLY.
2. Confirm that the Load being controlled is in proper working order. Local switch, ON (check for burned-out bulbs).
3. Confirm that the Load being controlled does not exceed the module limit.
4. Confirm that unit is programmed properly. Repeat "TO INSTALL" section to verify that it has been included in the Z-Wave™ network.

For additional information, contact Leviton's Techline at 1-800-824-3005 or visit Leviton's website at www.ViziaRF.com

U.S. & Foreign Patents Pending
Copyright© 2006 Leviton Manufacturing Co., Inc.
All Rights Including Trade Dress Rights Reserved

FCC COMPLIANCE STATEMENT

This equipment has been tested and found to comply with the limits for a Class B Digital Device, pursuant to Part 15 of the FCC Rules. These limits are designed to provide reasonable protection against harmful interference in a residential installation. This equipment generates, uses, and can radiate radio frequency energy and, if not installed and used in accordance with the instructions, may cause harmful interference to radio communications. However, there is no guarantee that interference will not occur in a particular installation. If this equipment does cause harmful interference to radio or television reception, which can be determined by turning the equipment OFF and ON, the user is encouraged to try to correct the interference by one or more of the following measures:

- Reorient or relocate the receiving Antenna.
- Increase the separation between the equipment and the receiver.
- Connect the equipment into an outlet on a circuit different from that to which the receiver is connected.
- Consult the dealer or an experienced radio/ tv technician for help.

DI-000-RZP15-00A

LIMITED 5 YEAR WARRANTY AND EXCLUSIONS

Leviton warrants to the original consumer purchaser and not for the benefit of anyone else that this product at the time of its sale by Leviton is free of defects in materials and workmanship under normal and proper use for five years from the purchase date. Leviton's only obligation is to correct such defects by repair or replacement, at its option, if within such five year period the product is returned prepaid, with proof of purchase date, and a description of the problem to Leviton Manufacturing Co., Inc., Attn: Quality Assurance Department, 59-25 Little Neck Parkway, Little Neck, New York 11362-2591. This warranty excludes and there is disclaimed liability for labor for removal of this product or reinstallation. This warranty is void if this product is installed improperly or in an improper environment, overloaded, misused, opened, abused, or altered in any manner, or is not used under normal operating conditions or not in accordance with any labels or instructions. There are no other or implied warranties of any kind, including merchantability and fitness for a particular purpose, but if any implied warranty is required by the applicable jurisdiction, the duration of any such implied warranty, including merchantability and fitness for a particular purpose, is limited to five years. Leviton is not liable for incidental, indirect, special, or consequential damages, including without limitation, damage to, or loss of use of, any equipment, lost sales or profits or delay or failure to perform this warranty obligation. The remedies provided herein are the exclusive remedies under this warranty, whether based on contract, tort or otherwise.

LEVITON INSTRUCTION SHEET/MANUAL SPECIFICATIONS

- Artwork No/Rev Level: _____
- Color(s): Black over DI-000-RZP15-00A
 1. _____
 2. _____
 3. _____
 4. _____
- Font Families: Helvetica
- Material
 - Type: 40 Lb. offset
- Coating: _____
- Paper size:
 - Overall size: 11" X 8.5"
 - Final fold size: 2.75" X 4.25"

DOCUMENTATION

- ECO No.: N/A
- Artist: H2D Date: 10/10/06

The information in this document is the exclusive PROPRIETARY property of LEVITON MANUFACTURING COMPANY, INC. It is disclosed with the understanding that acceptance or review by the recipient constitutes an undertaking by the recipient. (1) to hold this information in strict confidence, and (2) not to disclose, duplicate, copy, modify, or use the information for any purpose other than that for which disclosed.

Copyright © 1997 Leviton Mfg. Co. Inc.
Unpublished, All Rights Reserved

FOLD SCHEME

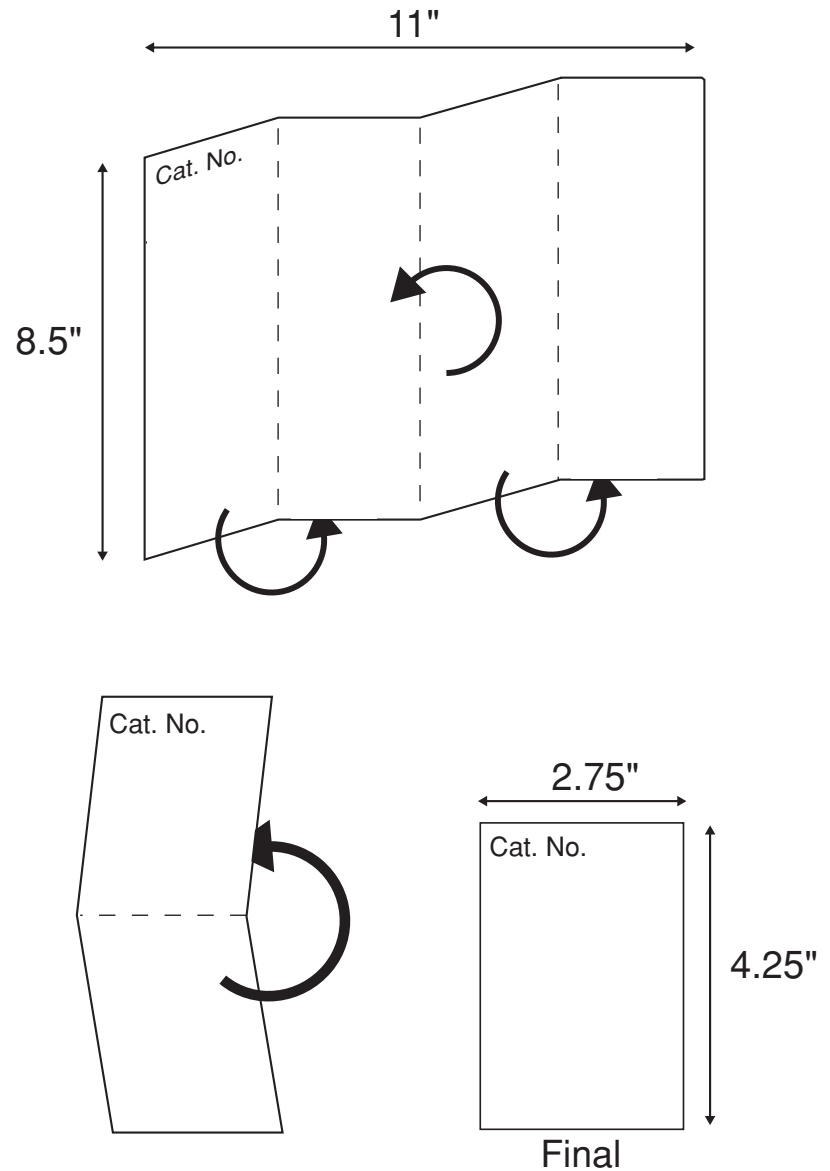

— — — Fold Line