

## M1XIN 16 Zone Expander Installation

1. Turn Control Panel Master Power Switch Off.
2. Install the two ELK-SWG Plastic Glide brackets. Slide board into glides.
3. Use 4 wire cable to connect terminals +VKP, Data A, Data B, and Neg from Control to terminals 12V, A, B, and Neg on the M1XIN. NOTE: If the zone expander is remotely mounted, refer to information on the back and in the M1 Installation Manual for important information about data bus devices connected to multiple homerun cables.
4. Set Address Switches according to chart below.
5. Power up the Control and the expander(s).
6. Use Keypad to access the Installer Programming Mode and go to Menu 01-Bus Module Enrollment. Press the right arrow key to start enrollment. To view the results, press the right arrow "edit" key.
6. Go to Menu 05-Zone Definitions and enable any of the new zones. Zone numbers printed on the boards are relative to that board only. The actual zone ID is based on the starting address setting.

NOTE: If it becomes necessary to replace an enrolled device, set the new unit to the same address and repeat the enrollment. If permanently removing a device, un-enroll it to prevent a trouble condition.

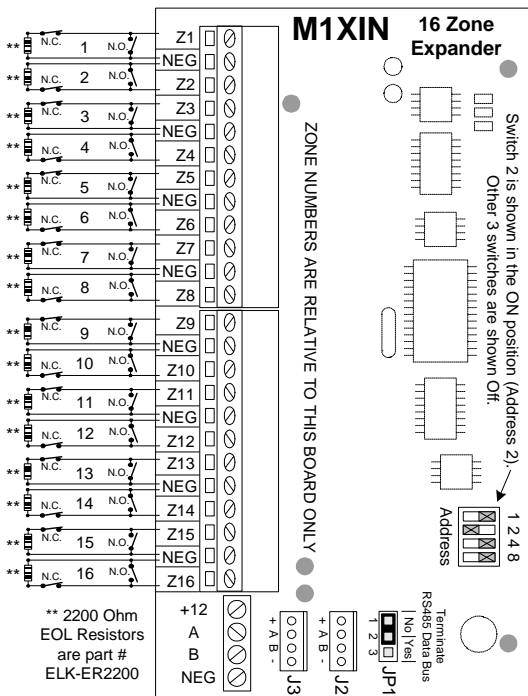

**ADDRESS SETTING:** Locate the four "Address" switches. Each has a position of OFF or ON (binary 0 or 1) with a decimal equivalent of (1, 2, 4, or 8). The total decimal value for the "ON" switches sets the bus address. This determines which inputs (banks of 16) are assigned to the expander. E.G. Address 5 would be set with switches 1 and 4 ON (1+4=5) and switches 2 and 3 OFF. Inputs Expanders are factory pre-set to address 2 (Zones "Inputs" 17 to 32).

Addr	Input Expander	Addr	Input Expander
1 =	N/A (main bd)	8 =	Zones 113-128
2 =	Zones 17-32	9 =	Zones 129-144
3 =	Zones 33-48	10 =	Zones 145-160
4 =	Zones 49-64	11 =	Zones 161-176
5 =	Zones 65-80	12 =	Zones 177-192
6 =	Zones 81-96	13 =	Zones 193-208
7 =	Zones 97-112		

# 16 Zone Expander ELK-M1XIN

## APPLICATION:

The **ELK-M1XIN** adds 16 hardwired zones (EOL resistor supervised) to the M1 or M1G Control. It operates on the 4-wire data bus and features flash memory which allows field updating of its operating firmware. Up to 12 zone M1XIN boards may be connected, increasing total zones (inputs) to 208.

**ELK**  
PRODUCTS, INC.

## 16 Zone Expander ELK-M1XIN



## FEATURES:

- 16 EOL Resistor Supervised Hardwire Zones
- Operates on the 4-Wire Data Bus
- DIP Switch Address Settings
- Flash Memory for Firmware Updating
- Plug-In Terminal Strips
- Status and Diagnostic LED
- On-Board EOL Bus Termination Jumper
- Vertical Mounting using ELK-SWG Glides (included)

## SPECIFICATIONS:

- Inputs: Plug-In Terminals with Elevator Style Wire Clamps and Screws
- Operating Power Range: 9 to 14 VDC
- Current Draw: 65 mA
- Size: 6" x 3.25" x .75" H

**ELK**  
PRODUCTS, INC.

828-397-4200 Voice  
828-397-4415 Fax  
<http://www.elkproducts.com>  
email: [info@elkproducts.com](mailto:info@elkproducts.com)

PO Box 100 • Hwy. 70W • Hildebran, NC 28637 • USA

**Instructions Printed On Inside**

# Input Expander Installed using an M1DBH Data Bus Hub

Since the M1XIN connects to the M1's RS-485 Data Bus, it can be installed inside the Control or virtually anywhere in between. The Data Bus requires only 4 wires, 2 for power + 2 for data. However, due to the relatively high speed of the data bus, special wiring connections are necessary to avoid data reflection errors on long cables OR multiple cable "homeruns". **See the M1 Installation Manual for important information about Data Bus termination, including methods and recommendations for avoiding data bus problems.** The primary goal is to have no more than 2 data bus branches (cables) running from the control, with each being terminated at its end using a 120 Ohm end of line resistor. There are two ways to accomplish this goal. 1) Using 4-wire cable, run no more than 2 cables and connect all devices paralleled (daisy chained) along this cable path. OR 2) Using 6 or 8 wire cables (CAT5 or CAT6 is ideal), run as many cables as you want so long as the data A & B wires are connected to a spare pair of wires so that they double back (return) to the control and are connected in series to the outgoing data A & B lines of the next cable. By keeping the data lines in a series circuit it will appear to be one long cable. This virtually eliminates data reflection errors. This is easily done using an ELK-M1DBH Data Bus Hub.

The M1DBH accepts CAT5 or CAT6 cable with RJ45 plugs on the ends. It internally connects the data wires in a series circuit. It also provides a clean, organized method for managing multiple data bus wires and provides a quick and easy way to perform end of line termination locally at the hub. This is done with an RJ45 Terminating Plug (included with ELK-M1DBH) placed into the first unused RJ Jack.

1. Pull Category 5 Cable (CAT5) from each data bus device to the control.
2. Terminate each CAT5 data bus cable with an RJ45 plug using the appropriate crimping tool. Use the 568A wiring standard (see wire color code below). **Note: RJ45 plugs are not included with the M1DBH. This is due to the great variety of brands and terminating tools which are subject to dealer preference.**
3. Following the color codes used in step 2, and the wiring diagram below, connect the CAT5 cable at each device. The Pos & Neg wires connect singularly to the Pos & Neg terminations (flying lead wires or terminals) of the keypad, zone expander, etc. However the data A & B lines connect to the device and a "return" wire so that the data returns back to the M1DBH which is used to feed the next device. This effectively puts the data lines in a series circuit so that the control communicates with each device in a progression or "daisy chain" fashion. The very end of this daisy chain requires a terminating resistor (see step 5). This is very important due to the high speed of the M1's RS-485 data bus communications.
4. Plug each data bus cable into it's own RJ45 jack on the M1DBH board, starting with J1. For more than 9 data bus cables, add a second M1DBH and connect the short CAT5 jumper (included) from J9 on the previous M1DBH board to J1 on the next M1DBH board. This leaves 8 jacks on the first M1DBH and 8 on the second or a total of 16 potential jacks (ports). Additional M1DBH boards may be connected for more cables.
5. Place the EOL resistor terminating plug (included) into the first unused jack. This plug places a 120 Ohm resistor across the A & B data return lines coming from the last wired device and terminates the bus.

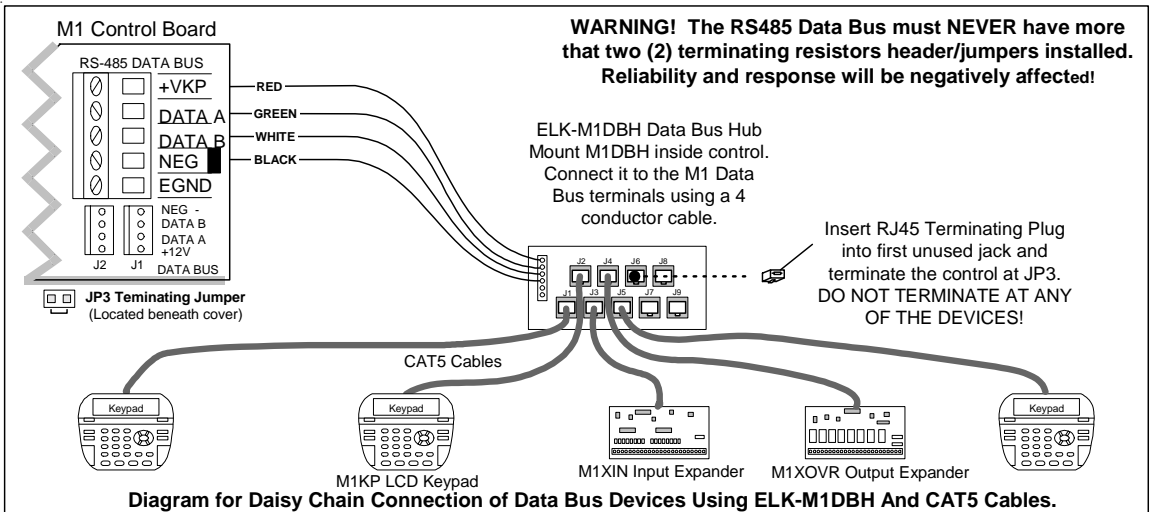

**Maximum "TOTAL" Length of the M1 RS-485 Data Bus should NOT exceed 4000 feet.** When calculating total length, figure length of each home run to the M1DBH times 2 (x 2) since the data lines run out and back. Maximum number of data bus devices varies by control.)

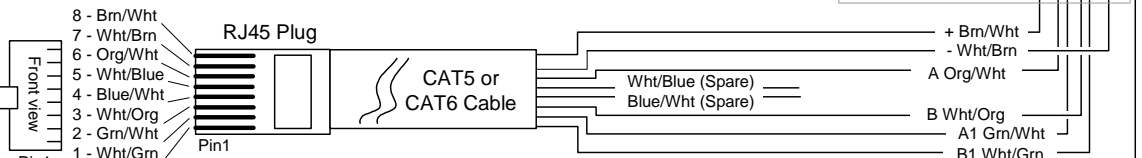

**Color Code and Connections of CAT5 or CAT6 Data Bus Cable from Input Expander to Data Bus Hub**